

Love isn't on hold...

Let's not pause love.

Hire one of our beautiful backdrops for an intimate wedding celebration. Starting from £500*.

Contact us, let's get excited together!

8



RSA
The
Royal Society for
the Encouragement of
Manufactures
& Commerce



*T&Cs apply

RSA Journal

Issue 3 2020

The great economic shake-up

Our economies and societies need to be reordered, writes **Asheem Singh**

Anne Price explains the deep-seated roots of racial inequality

Deirdre McCloskey makes the case for liberalism





LOCATION LOCATION LOCATION



Book us for your next filming, interview or location shoot. A striking Georgian Townhouse; rich in history and contemporary in style. Featuring 11 unique spaces and many authentic features including a door similar in date and style to the iconic 10 Downing Street door.



Safely reconnect with colleagues in an inspiring environment. Room hire from £75. Offering new creative menus and excellent service.

T&CS APPLY

Patron of the Society

HM The Queen

President

HRH The Princess Royal

Board of Trustees

Chair

Tim Eyles

Deputy chair

Philippa Wilson

Treasurers

Stephen Gleadle

Jill Humphrey

Lucy Griffiths

Andrea Kershaw

Sam Lewis

Shonagh Manson

Charlotte Oades

Nick Parker

Jan Portillo

Shaifali Puri

John Towers

Affiliate Chairs

Oceania

Mark Strachan

United States of America

Ric Grefé

Fellowship Council

Programme Councillors

Sarah Beeching

Jan Floyd-Douglass

Christine McLean

Don McLaverty

Peter Quirk

Tom Schuller

Matthew Treherne

Nation/Area Councillors

Global

Nishan Chelvachandran

Enrique Mendizibal

Executive

Chief executive officer

Matthew Taylor

Chief operating officer

Natalie Carsey

Chief research and impact officer

Anthony Painter

The RSA (the royal society for arts, manufactures and commerce),

8 John Adam Street,

London WC2N 6EZ

Tel +44 (0)20 7930 5115

www.thersa.org

Registered as a charity in England and

Wales, no. 212424 and in Scotland no.

SC037784

RSA Journal, Volume CLXVI

No. 5583, Issue 3 2020

ISSN: 0958-0433

RSA Journal

Editor

Milena Bellow

(editor@rsa.org.uk)

Creative director

Ben Barrett

Senior designer

Johan Shufiyan

Publisher

Emma Fisher

Production director

Angela Derbyshire

Production manager

Jack Morgan

Chief executive, Wardour

Claire Oldfield

Executive chairman, Wardour

Martin MacConnol

Commissioning editor

Rachel O'Brien

Distribution

Vanessa Woo

The RSA Journal is published

for the RSA by Wardour,

2nd Floor, Kean House,

6 Kean Street,

London WC2B 4AS

Tel +44 (0)20 7010 0999

www.wardour.co.uk

North

Melanie Hewitt

Paul Ingram

Central

Clare Gage

Rachel Sharpe

South East

Denise McLaverty

Eileen Modral

South West

Neil Beagrie

Peter Jones

Fellowship Council (FC) chair, FC deputy chair, FC Trustee and Nominations and Governance Panel are pending appointment in the new council



The RSA Journal is printed on 100% recycled paper; which is Forest Stewardship Council certified and Carbon Balanced.

© The RSA. All rights reserved. Reproduction in whole or part prohibited without prior permission of the RSA. The RSA and Wardour accept no responsibility for the views expressed by contributors to the RSA Journal, or for unsolicited manuscripts, photographs or illustrations, or for errors in articles or advertisements in the RSA Journal. The views expressed in the RSA Journal are not necessarily those held by the RSA or its Trustees. For more information about how we use your personal data, visit www.thersa.org/privacy-policy.

Matthew Taylor



“It is vital that we redouble our efforts to secure good work for all”

With unemployment rising and the UK facing the twin challenges of Covid-19 and the inevitable disruption of Brexit (whatever form it finally takes), the emphasis of policy and public concern is on economic recovery. Yet the economy going into the pandemic, although strong in some regards, such as the level of employment, also had many profound failings, including precarious employment and high levels of in-work poverty. A question posed by this edition of *RSA Journal* is whether policymakers and citizens have the imagination, determination and realistic capacity to build a fairer, more fulfilling, more sustainable economy out of the ashes of the old.

This is certainly an issue being wrestled with in the EU, as Zsolt Darvas describes in his article. The European recovery fund is a glass half full phenomenon. On the one hand, it is not bold enough either in its scope for redistribution to Europe’s most financially frail countries or in the investment needed to green the economy. On the other hand, it could mark a decisive shift towards more solidaristic integration and the ambition for Europe to lead the world in tackling greenhouse gas emissions and other environmental harms.

Europeans, especially in the north and west, are long used to the idea of industrial partnership at the national and organisational level. Indeed, in countries like Germany, corporatist structures helped craft policy responses to Covid-19 and win support for them among the public. As my colleague Asheem Singh argues, we need to deepen the conversation about working lives as we rebuild. The crisis has made people more sensitive to the plight of precarious workers and underlined the gap between the social and market value of key workers ranging from care home staff to parcel couriers. But mass unemployment focuses minds more on the quantity than the quality of work, and there is evidence from the RSA and elsewhere that the pace of automation has accelerated.

The progress towards better work was slow before Covid-19 but at least in the right direction. It is vital that we redouble our efforts to secure good work for all. As Harris Eyre FRSA argues in his piece, we need work that enhances, not detracts from, our wellbeing and creativity.

In her article, Saba Salman FRSA urges us all to include people with disabilities in the commitment to fair and diverse workplaces. And the RSA’s Mark Londesborough explores how many schools have reached out to communities in their response to Covid-19, and how they need to reach out again to help tackle the plight of excluded pupils.

When it comes to social justice and sustainability, taken up respectively by Anne Price and Alexandra Pinzón Torres, a big question is whether change can be achieved incrementally or if it requires a more profound shift away from the capitalist system. In her fascinating interview, Deirdre McCloskey encourages us to separate the dynamic, freedom- and progress-enhancing qualities of markets from specific models of capitalism, which, after all, vary significantly from nation to nation. In similar vein, Michelle Meagher explores the weakness in the regulatory framework governing competition. Covid-19 has made the global tech giants even richer and more powerful. Their unprecedented economic and political power comes with little accountability. This, too, must surely change. Another challenge to economic orthodoxy comes from the ideas of modern monetary theory, which are explored by Bill Mitchell, one of its leading exponents.

Even a green, post-Covid-19 economy will rely on consumers; in her Last Word piece, consumer psychologist Kate Nightingale argues that obituaries of bricks-and-mortar retail are very premature.

As we struggle through what will no doubt be a tough winter, I hope this journal and the wider content and community offered by the RSA provides reasons, if not to be cheerful, at least to be hopeful. ■

Matthew Taylor is
Chief Executive of
the RSA

ISSUE 3 2020

Long read



10 Reimagining the economy

We should use this time of change to create new imaginaries and a future focused on the collective good, asserts Asheem Singh

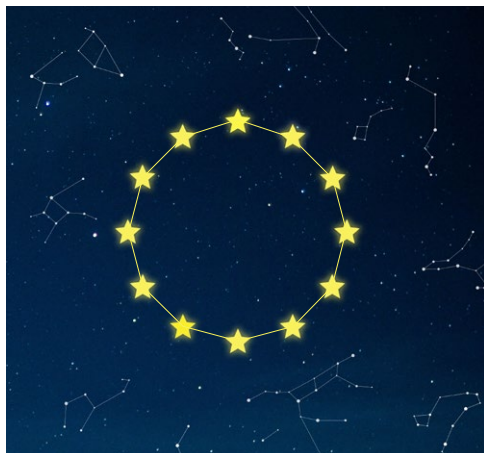

22 A new solidarity?

Zsolt Darvas looks into the EU's response to the Covid-19 crisis

Medium read



16 In conversation

Matthew Taylor has a discussion via email with economist Deirdre McCloskey



36 The nature of things

Alexandra Pinzón Torres proposes ways to create a more sustainable economy



28 Root of the matter

Covid-19 has highlighted and exacerbated longstanding historical inequalities, writes Anne Price



44 The brain economy

Harris Eyre and co-writers put forward the case for an economy that centres on brain health

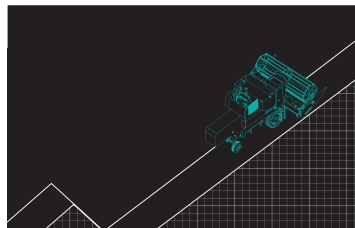

32 Winner takes all

Our competition laws need to catch up with the changing face of business, says Michelle Meagher

Short read



20 Access all areas

We should ensure that our workplaces are inclusive for all, writes Saba Salman



35 Does MMT add up?

Bill Mitchell makes the case for modern monetary theory



40 Unsteady foundations

The built environment is essential to social cohesion, explains Marwa Al-Sabouni

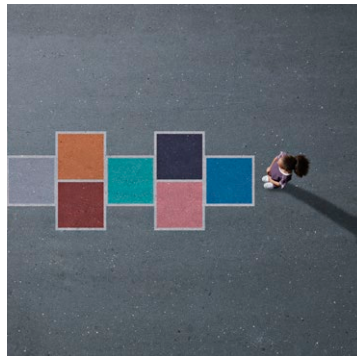

42 Post-Covid-19 schooling

The pandemic has shown that schools offer far more than education, says Mark Londesborough

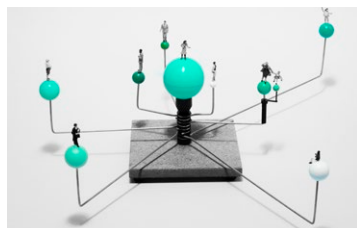

48 Global

Fellows around the world are working together to develop solutions to the problems highlighted by Covid-19



50 Last word

Kate Nightingale extols the virtues of bricks-and-mortar shops

Periscope

- 1 The “hedonic treadmill” describes the short-lived satisfaction of meeting one set of needs only for them to be replaced by another set (page 10).
- 2 Liberalism, according to philosopher T.H. Green, is the “capacity of doing something worth doing” (page 19).
- 3 Less than 6% of learning-disabled people in the UK are in paid work (page 20).
- 4 On 21 July, the European Council agreed on the creation of an EU recovery fund, Next Generation EU (page 26).
- 5 In 2019 in the US, the typical Black household held about \$24,100 in wealth; a typical white household had nearly eight times as much (page 28).
- 6 In the UK, four supermarkets control 70% of the groceries market (page 32).
- 7 It is estimated that the world needs to spend \$722bn–\$967bn per year over the next 10 years if we are to tackle biodiversity loss (page 36).
- 8 In the UK in March–July this year, children missed 575m school days (page 42).
- 9 Mental health disorders are estimated to cost the global economy \$2.5tn–\$8.5tn per year in lost output (page 44).
- 10 Research has shown that “smellizing” (prompting people to imagine the smell of a product) increases product engagement (page 50).

Work



Transforming the future of work

Work that works for all

Changing consumer trends, public health measures and the cost of labour in the pandemic are all aiding the rise of robots and increased automation, according to new RSA research.

The report – *Who is at Risk? Work and Automation in the Time of Covid-19* – published in October, is the first piece of work to form part of the RSA's new Future of Work programme.

The report explored how the pandemic might accelerate

technological change and forever alter the future of work and, not surprisingly, highlighted that the sectors most affected include accommodation, clothing manufacturing and retail. However, it found that many viable jobs in 'automation-proof' sectors like the arts and entertainment are also at risk. The report called for targeted support to protect jobs at risk because of Covid-19 and automation, including transition services and upskilling for workers at risk.

The Future of Work programme aims to make sure that everyone (regardless of background) can pursue good work in an age of technological change. For example, the RSA is working with Mastercard and Bayes Impact to test an innovative approach to lifelong learning via a digital careers and employability coaching platform. This will help 100,000 low-paid workers in France in 2021, with a smaller pilot planned for launch in the UK in early 2022.

■ To find out more, contact the Future of Work programme team on futureofwork@rsa.org.uk or visit www.thersa.org/future-of-work

Heritage

Heritage Index 2020

The City of London continues to hold the top spot in England in the RSA's Heritage Index, a tool for understanding and quantifying local heritage assets. The RSA's third iteration of the Index, which uniquely brings together over 100 data points from across the UK to quantify heritage assets, found that Belfast, the Orkney Islands and Conwy in north Wales lead the rest of the UK.

The Index includes areas and structures – such as beaches, landscapes and listed buildings, among others – and activities, including funding awards, community engagement, blue plaques and local participation. It found that areas in the south-east, including Castle Point and Rochford, display the most heritage potential; that is, they have a wealth of heritage assets but comparatively low activities surrounding them.

The data included in this year's Index paints a picture of the heritage sector in early 2020, as data collection ended before the Covid-19 crisis began. In recent months, the sector has moved to a critical juncture, with many organisations at risk as lockdowns continue to various degrees. The RSA hopes that the Heritage Index will provide an evidence base to show the kind of support local areas might need in the short term, and how, in the longer term, the heritage sector might help wider recovery plans.

■ To find out more, visit www.thersa.org/reports/heritage-index-2020

Image from Getty

RSA insights

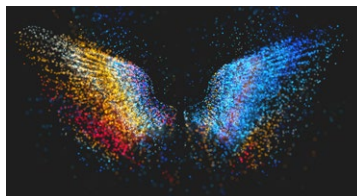

Adopt a playwright

Each year, the Adopt A Playwright Award, founded in 2008 by Sofie Mason and Diana Jervis-Read FRSA, gathers a family of 30 'Angels' together from every walk of life to build a community around one playwright. They raise £8,000 to give the writer the time and economic security in which to write their next play. The aim is to ensure that talented new writers from diverse backgrounds, who may have little encouragement or financial support, are given a fair chance to take their place among our culture's storytellers.

■ To find out more, visit www.offwestendplaysandplaywrights.com

58%

The majority (58%) of key workers said that they struggled to maintain their mental health during the first lockdown, according to a new report by the RSA. The first in a three-part series looking at the economic security of key workers, it found that this was a particularly acute problem for NHS staff (with 64% saying they found maintaining their mental health more difficult) and for social care and supermarket workers (61%).

■ To find out more, visit www.thersa.org/reports/clapped-out

66%

Two-thirds of respondents to a survey commissioned by the RSA believe more people should be supported to live at home rather than needing to move into residential care. Conducted by Opinium, the survey also showed that a quarter of people thought individuals should be given more say over their health and social care support. The survey forms part of an RSA project that proposes the establishment of a People's Health and Care Commission, which would help to develop a more equitable health system.

■ To find out more, visit www.thersa.org/reports/future-health-social-care

£100bn

The cost to the economy of poor health due to lost productivity is estimated to be around £100bn. A new report published by the RSA with the Health Foundation and Demos Helsinki highlighted that good health is vital to a thriving economy and examines how economic development can be used to improve people's health and reduce health inequalities in the UK. It outlined the steps that can be taken, drawing on case studies in the UK and internationally, and found that, among other factors, strong local leadership and capitalising on local assets are critical.

■ To find out more, visit <https://bit.ly/32LjhHO>

Agenda

Catalyst Awards



The RSA has given out £100,000 Catalyst Awards annually to support Fellow-led projects since 2010. Grants are awarded to projects that aim to make a positive social impact in areas that broadly align with the RSA's programmes (currently Future of Work and Regenerative Futures) and projects.

Claire Doran, the Interim Catalyst Fund Programme Manager, said: "The Catalyst Awards are an important way we live out the RSA's principles of uniting people and ideas to resolve the challenges of our time. By collaborating and working in alignment, we believe we can best achieve wider systems change."

There are two kinds of Catalyst Awards: £2,000 Seed Awards, which aim to help get a project off the ground and to enable Fellows to test out their ideas; and £10,000 Scaling Awards, which allow projects to expand at scale and achieve wider social impact. In both cases RSA support is integral; recipients are allocated a dedicated member of staff as a point of contact for the duration of the funding, offering guidance and exploring ways for the project to connect with the RSA community.

The Catalyst Fund programme opens for applications three times a year, with the next round in February 2021. The brief and criteria for each round will be updated on the RSA's website with full guidance on how to apply.

■ You can find out more at www.thersa.org/fellowship/catalyst-awards. If you have any questions about applying, contact the Catalyst team on +44 (0)20 7451 6895 or catalyst@rsa.org.uk

Fellowship

New Fellows

Dr Abubakar Bukar Kagu is a Senior Lecturer in Law and Director for the Center of Research and Capacity Development on Humanitarian Studies at Yobe State University, Nigeria. He helped to ensure the first child's protection law and the administration of criminal justice law of Yobe State came into effect. He has also worked closely with organisations such as the National Human Rights Commission.

Adele Fraser is committed to the growth and development of the social rented housing sector in Scotland. As Chief Executive of Linstone Housing Association, she leads a community-based housing association with 1,600 tenants and 50 staff. Linstone is recognised as a community anchor organisation and is working closely with the local community.

Make the most of your Fellowship by connecting online and sharing your skills. Search the Fellowship at www.thersa.org/fellowship. While you're there, don't forget to update your own profile: www.thersa.org/my-rsa.

■ Follow us on Twitter @theRSAorg
Our Instagram is www.instagram.com/thersaorg
Join the Fellows' LinkedIn group
www.linkedin.com/groups/3391

Where possible, Fellowship events have moved online; to find out more and connect with Fellows in our global community visit www.thersa.org/events/fellowship

Grow your idea through RSA Catalyst, which offers grants and crowdfunding for Fellow-led and new or early-stage projects with a social goal.

■ To find out more, visit our online Project Support page www.thersa.org/fellowship/project-support

Events



Catch up online

At a time of global crisis, RSA Events is hosting a new series of online conversations with leading public thinkers. Our speakers explore what this emergency reveals about our economies, our societies, ourselves – and how we might shape new ways of learning, working and caring for each other, creating more secure, sustainable lives and livelihoods for all.

■ *Subscribe to our YouTube channel and 'like' us on Facebook to catch up on the latest content*

▶ www.youtube.com/thersaorg

▶ facebook.com/rsaeventsofficial



How to be an anti-racist educator

Zahra Bei and **Rodeane Henry-Grant**, both of the Coalition of Anti-Racist Educators; **Sarah Brownsword**, a lecturer at the University of East Anglia; and **Daniel Kebede** of the National Education Union share perspectives on what it takes to turn the discourse of anti-racism into the practical, sustained, everyday actions that will be vital to securing a fair education for everyone.

■ *Watch now: youtu.be/natj24mIGks*

■ **#RSAEducation**

How to make the world add up

Statistics are vital in helping us tell stories and make sense of the world – and yet we doubt them more than ever. Amid a sea of obfuscation, economist **Tim Harford** and data bias campaigner **Caroline Criado Perez** show how to seek out the numbers with the power to inform and illuminate.

■ *Watch now: youtu.be/RrI0cQey-Ss*

■ **#RSANumbers**

Can business save the world?

The excesses of capitalism left unchecked are catching up with us in the form of inequality, environmental breakdown and institutional collapse. Harvard economist **Rebecca Henderson** calls for business, which has until now been part of the problem, to become part of the solution.

■ *Watch now: youtu.be/sq6KokzrA_c*

■ **#RSAEconomy**

Active democracy in times of emergency

Can a more active democracy break political deadlock, build civic trust and drive transformative collaboration between government, civil society and communities? **Claudia Chwalisz** of the OECD; **Panthea Lee**, co-founder and Executive Director of Reboot; and **Graham Smith** of the University of Westminster explore practical strategies for long-term change.

■ *Watch now: youtu.be/UXMrMjIkNkU*

■ **#RSADemocracy**

REIMAGINING THE ECONOMY

This is a time for transformation, not reversion

by Asheem Singh
 @RobinAsheem

In the criminally underrated British 1980s cult movie *How to Get Ahead in Advertising*, Richard E Grant plays an advertising executive called Dennis Bagley who has a nervous breakdown over selling a pimple cream. He comes to realise that his life selling pointless things to people who do not need them is harmful, is killing the planet and is making us all not just unhappy, but insane.

Bagley's wider argument – which he makes in a series of increasingly deranged rants – is that our ever-expanding culture of consumerism feeds an ever-ravenous capitalist beast that exploits labour for no other reason than its own enlargement. Spoiler alert: in the end, he gets better and becomes himself again, but in order to sell his pointless tincture, he has to level up. He thus becomes capitalism personified in one figure: a grotesque, hypersexed, tall-tale-teller extraordinaire.

So far, so Marx. Yawn away, but there is a reason that this kind of critique cuts through in our time, with double the violence: social media. The era of social media has accelerated the psychic reach of capitalism to ever-more grotesque proportions. On Twitter or Facebook or in the Apple App Store we are not only consumers but labourers; each time we tweet or update our status or upload a photo we are effectively clocking in. We are not only buyers of an

online service, but workers on its production line, donating our labour for free in order to build lucrative networks through which information and money flow freely. Corporations call this 'community'. Bagley calls it 'Jerusalem' as he looks out over England's green and pleasant land and extolls the virtues of fad diets and foot deodorisers. Harvard academic Shoshana Zuboff calls it "surveillance capitalism", which I believe is the most accurate description yet.

The great tech corporations realised early on in the millennium just how monetisable we all were. Purveyors of *The Cluetrain Manifesto* – a 'how to' guide for nascent internet-bubble businesses published in 2000 – sat in circles intoning sagely that "markets are conversations". Two decades on and we realise how wrong they were. We have less conversational agency than ever in the era of algorithms, artificial intelligence and machine learning. Gaslit into giving up data and labour for the sake of vanity and transitory serotonin highs, we are enjoined in a virtual assembly line from which there is no escape.

In the early 1970s, American psychologists Philip Brickman and Donald Campbell spoke of the "hedonic treadmill" to describe how the satisfaction of meeting one set of needs is short-lived and simply lays the foundation for another set. That treadmill is our daily





“You cannot just will an imaginary into being, or write a smart article and wait for others to catch on”

reality, kept in motion at our own behest. The resulting system is a self-inflicted prison. The door is open and we can theoretically leave at any time, but we dare not. And yet the truth of it all is that we can leave, but it takes more than willpower: it takes nothing less than a moment of collective re-imagination.

Gods and Monsters

Underpinning every age are imaginaries: Gods and Monsters that sit at the level of the general subconscious and compel citizens to obey social codes. We see them in literature, art, culture and governance: psychic forces that tug at our in-built affection for solidarity and group behaviour. The concept of God has historically played this role with aplomb, whether in medieval Europe or, say, in the caste system of predominantly Hindu India, a uniquely stratified society mediated by ritual and myth. The Enlightenment saw the birth of a new set of imaginaries and the 20th century saw the birth of the term, courtesy of philosopher and novelist Jean-Paul Sartre. The imaginaries of this time were rooted in the democratic nation state: a common culture, bonded in rational discussion in the public square.

Note that the term imaginary is not pejorative: it is not designed to poke fun at sincerely held beliefs. Rather it is an attempt to understand the great, unseeable forces that bind humans in structured, Apollonian endeavour. The Industrial Age brought its own imaginaries. The Russian-American writer Ayn Rand would in the 20th century valorise the Carnegies and the Rockefellers, the buccaners of the age who took the Panopean clay of capitalism and from it wrought an imaginary of individualist excess, buttressed by the codes of rationalism and even racism.

That imaginary holds today. Tech oligarchs and media plutocrats borrow from the imaginaries of yore to create a trope I call the ‘tech god’. In the cultural consciousness they embody the omnipotence of a deity and the swashbuckle of the pirate, melding with something new: the kindness of community, the generosity of ‘free stuff’ and sophisticated tools that speak to each of us. They bring science and reason: an invisible, energy-sucking, numbers-based glue to prove this hegemony.

These imaginaries consolidate the monopoly capitalism of the tech industry. Today, the great corporations are more powerful than banks, than

certain states, with unparalleled wealth in the hands of so-called superstar firms and an ever-increasing slice of global GDP moving from labour into their grasp.

The imaginaries of any age are without borders. They extend beyond the corporate world and seep into public life. The tech savant imaginary was translated for the political sphere by Benedict Cumberbatch in the Channel 4 film *Brexit: The Uncivil War*. There is little doubt that his performance helped cement in the popular imagination the idea of Dominic Cummings, a hitherto obscure political staffer, as a t-shirted data guru/genius in the Mark Zuckerberg mould. The recognisable shorthand here shows just how far the imaginary has set in.

That we imagine that in our time, in our deepest intuitions, government is rightly run by figures like these is telling. It shows how divorced our imagination is becoming from the everyday reality of good governance. We have seen the reality behind the imaginary as we have moved through the Covid-19 pandemic. Consider, we have this past year dealt with a once-in-a-century moment: over a million dead globally, lockdowns, the social safety net frayed beyond recognition. Yet the imaginary has conditioned both the policy response and our response to the policy response. First, we were desperate to continue to feed the productivity beast. We needed to get workers back to offices to keep our inner cities going, it was said. We needed to get children back to school so parents could go to work, it was said. We needed to get students into halls so property developers would not be out of pocket, it was said.

The Bank of England followed suit, insisting that everything would go back to normal very soon. Even usually sensible commentators spoke of a “V-shaped recovery”. When it was revealed that the months to May 2020 had seen Britain’s biggest economic contraction since records began, these same commentators confidently pronounced that in the next quarter we would bounce right back.

Toxic productivity

This was magical thinking rooted in the imaginary I refer to as toxic productivity. Commentators including myself looked on with increasing incredulity as the government struggled to get their heads around the idea that people will not go back to the shops unless they feel safe. We tried to get the government to change tack. It is not the lockdown that is causing the recession, we repeated over and over, it is the virus. Yet the idea that this was a moment for economic transformation, rather than economic reversion, was jettisoned by a beleaguered and rudderless officialdom who could imagine no other way.

Policymaking in a pandemic is hard, and the purpose of this exposition is not to minimise these difficulties but to demonstrate how imaginaries cripple the thinking of even smart people, often without them realising it, and put them in a position where they advocate irresponsible things. It was widely rumoured early on, for example, that the UK was to follow Sweden in adopting a ‘herd immunity’ approach to the virus. This was based, so we were told, on internal data produced by a special unit at the heart of government: another sop for the imaginary.

Even a cursory analysis would reveal this to be an irresponsible plan; it is absurd to think that a new virus like this was intelligible in terms of viruses that had come before. But the fish that swims against the current has metastasized via the world wide web and converted this niche position into a dangerous, fissiparous orthodoxy. This irresponsible position even now inspires fervour across the globe.

The UK government department that has been most infected by the imaginary of our time has been the Treasury. This is not the place for a detailed analysis of its performance; suffice to say that, while the furlough scheme was a genuinely innovative product, a measure in line with governments the world over that brought relief to so many, the Treasury’s work overall has been lacklustre. There have been 10 fiscal statements in the past year, including four Winter Economy Plans. There is everything right with giving government departments space to experiment and fail. However, this kind of product development by iteration – an imaginary often associated with the tech god – is absolutely unfit for purpose when it comes to national fiscal policy that affects millions.

The Treasury was, not uncoincidentally, also responsible for the most irresponsible policy enacted by a government in recent times: the Eat Out to Help Out scheme. A study was published in October that essentially affirms the harm this scheme caused. Eat Out to Help Out embodies many of the follies of the imaginaries of our time: a hunger for productivity, the desire for the harmful ‘normal’, the undergirding belief in the positives of herd immunity and, of course, the tech-bro desire to ‘just try something’, regardless of the cost. The UK’s economy, Chancellor Rishi Sunak said, is uniquely dependent on hospitality, and so he thought he would spend taxpayers’ money on a massive subsidy.

All of which demonstrates an essential immorality at the heart of the thinking. Just because we are a nation of Pizza Express and Burger King lovers does not mean it is the place of a good government to encourage such habits. At a time when medical experts everywhere repeatedly advised that, in order ▶

to combat the pandemic we should reduce our waistlines, stay healthy, boost our immune systems, stay at home and socially distance, the government spent public money to get us out to eat badly. The lines outside restaurants like McDonald's went for blocks and were of course the longest in the poorest areas. This was hailed by complicit journalists and commentators as a wild success. The Treasury no doubt still considers it so, even as Britain went right into a second lockdown a month or so later, citing rising infection rates, in part as a result of this orgy of bad eating.

Some will say that restaurants should not alone be blamed for the so-called second wave, but this is to miss the point. The immorality at the heart of our policymaking in response to crisis is sanctioned by the imaginaries of our time. The collective adulation for death-wish schemes are part of this too. This is Dennis Bagley-level collective derangement. Isn't it?

RSA Fellowship in action

Back & Fill

The idea for Back & Fill, a series of artist-led festivals, germinated in the early days of the Covid-19 lockdown as Kate Kneale and Dan Thompson (both FRSA) watched while the country started to shut down and events were cancelled. "We wondered if there was a way to work positively together instead of just mourning the things we were losing," says Kate. "It was also about putting a marker on the horizon to give us something to look forward to." Based in Margate, they realised that coastal towns would be particularly hard hit by Covid-19 and wanted to create something that would encourage people to visit those destinations once it was safe to do so again. They developed Back & Fill, and festivals took place in seaside towns across the country in October. The project was awarded a £2,000 RSA Catalyst Seed Grant, which was used to set up a website, commission artists for the Margate event and create an open-source toolkit for all those looking to set up their own festivals.

"The support from the RSA has been hugely important," says Kate. "We were trying to dream something big into existence and knowing that there were other people out there who felt this was an idea worth supporting was really important."

Festivals took place in 12 seaside towns, with activities ranging from Operation Zombie (an immersive theatre experience), to treasure hunts, history walks and exhibitions. Each was locally organised, and it is hoped that some will continue to take place annually.

■ To find out more, visit <https://backandfill.uk>

The need for new imaginaries

Our only hope, it seems, lies in somehow shifting these imaginaries, pulling them away from the clutches of corporate power. By definition, however, imaginaries are not easy things to dislodge. They are emblematic of an age, are themselves cultural artefacts. They are not of one place or person, but a product of all of us.

You cannot just will an imaginary into being, or write a smart article and wait for others to catch on. Take the archetype of the hungry lascivious capitalist, located in the later Dennis Bagley but also in one Donald J Trump. It is not enough to simply say 'we think Trump types are bad, so we're not going to valorise them any more'. As we've seen with the US election, the phenomenon of 'shy Trumplers' and the attempted coup in the aftermath, many people simply will continue to tacitly respond to that trope and even bend the system to the imaginary's will, no matter the consequences or contradictions with their professed morals or virtues. The imaginaries of an age flow not from government edict or policy prescriptions or the wishful thinking of the earnest, but from the deepest cultural touchstones: art, popular culture, religion and a shared response to our time.

I am optimistic by nature – though not, I hope, Panglossian – and I sense a shift here; a response to what has come before. In our time of accelerated shared experiences via the web (its saving grace), things flip quickly. I believe we are beginning to see – vaguely, in outline – the emergence of a contrasting set of imaginaries. Let me end by discussing them.

Laying the foundations

First, there is the emerging imaginary of a new kind of empathic leader. The toxic masculinity of our leaders of yore compares unfavourably to a new breed of leader. Empathic, collaborative, often women; leaders like Finland's Sanna Marin, New Zealand's Jacinda Ardern and America's Kamala Harris inspire followers but also devotees.

The psychic pull of this idea is powerful – quite different, I think, to any culturally popular female embodiment of leadership that has come before, which was often located in goddesses or warrior queens. This kind of leadership eschews the individual deism of those types. It distributes power and so is even more powerfully realised when plugged in to the internet, where civil initiative amplifies all.

This is the second imaginary: the empowered civil society. We are used to seeing civil initiative being deployed by unscrupulous politicians and magnates to foment division and consolidate their power. Many online movements serve cults of personality. Yet that which is used for bad can also be used for good. Coupled



with a new kind of empathic leadership, an imaginary of patient, distributed civil initiative that rights historic injustices is also taking root. The Black Lives Matter movement is part of this. Where it does this well is not so much when it fights online fire with fire or pitches right against left but where it stands against the cults of any one personality and distributes leadership and responsibility widely. We see the admiration for civil society throughout contemporary pop culture, in a slew of high-profile movies about ‘Hidden Figures’ (the name of one such) of the protest movements of recent history. We see it in social thought, in the actor-network theory of Bruno Latour that eschewed the heroic model of innovation in favour of the analysis of innovation networks and their practices. We see it even in video games played collectively and collaboratively online, or the minimalist music of Steve Reich that gives space to multiple listeners to collectively create the auditory experience.

We also have seen it up close in key RSA projects. For years, the RSA has been part of a so-called deliberative wave of thought and experimentation across Europe, convening deliberative experiments. Now, based on that experience, my team and the RSA US are joining forces to advise a national group of councils on embedding world-class deliberative practice into their economic decision-making, with a view to happier, greener economic development.

The RSA’s Forum for Ethical AI project alerted us to the power of convening discussion among workers of all stripes, in this case on complex technological

matters. Ordinary people, given space and agency, could understand and even effectively regulate complex tech, provided the group is diverse and given agency and the tools to collaborate. Applied to politics and thought leadership, this is a *cri de coeur* for a more equal distribution of agency, voice and power.

Which brings us to a third imaginary: our evolving idea of the balanced mind. No doubt our collective experiences in lockdown have shaped our rising awareness of mental (un)wellness. This, happily, is leading to a greater focus on self and collective care. As our awareness has increased, we are starting to perceive more tangible connections between the individual and the collective, our lives as mediated not by machines or businesses but by nature, ecology and collective good. This is the locus of the RSA’s new Regenerative Futures programme of thought and practice. Its projects intentionally sit at this intersection, bringing policy and practice into alignment in order to – if I may put it this way – resolve the collective challenge of being with a collective approach to becoming. Working together, in synchronicity with the world, rather than enslaved to the caprice of man: this is the ultimate rejoinder to the Dennis Bagleys of this or any other age.

Such are the foundations of a new set of imaginaries for our times. Will they lead to cultural and political awakening, to growth and change? We at the RSA will continue to prove their limits. No doubt we will learn more of their collective capacity to inspire wonder and action in the months and quarrels ahead. ■

“What made us rich was being liberated”

Matthew Taylor chats with Deirdre McCloskey, via email, about liberalism, capitalism and the state of economics today

Matthew Taylor: You’ve had a very varied career. Could you give us a brief outline?

Deirdre McCloskey: I think of my career in the way the naughty American comedienne of the 1930s, Mae West, thought of hers: “I was Snow White. But I drifted!” Trained as a Snow-White Keynesian and engineering economist at Harvard, I drifted into British economic history, approaching it in a free-market, Chicago-School way before becoming a professor of economics and history, where I shifted direction again, to ancient rhetoric and modern literary studies, as a supplement, not a replacement, for supply-and-demand economics. The 1990s saw more drift: into so-called ‘Austrian’ economics, meanwhile changing gender (I was born as ‘Donald’) and becoming an Anglican. Quite a decade, you might say.

Since age 73 I’ve been retired, which gives more time for scribbling. I scribble for various academic journals, and in the decade past a good deal of opinion journalism has been thrown in. You can look on all this as a dog’s breakfast, I suppose, or more charitably as gradually getting the point: which is “humanomics”, an economics with the humans left in. And along the way, I’ve written a couple of dozen books.

Taylor: It would be interesting to hear more about your shift from economics to history and how it has changed your view of the discipline.

McCloskey: I was at age 16 a socialist, at 20 a Keynesian, at 27 a liberal. What struck me is that

the cadres of each disdain all the others. I found myself asking how economists really argue: not how they say they do, but how they truly do. How can they disagree, if all are Scientists, and the Method of Science is what you learned in fifth-form chemistry? I rediscovered the main conclusion of science studies since Thomas Kuhn: that scientists are humans, and therefore they argue in human ways, with metaphors and stories, models and data, authority and images, ethics and politics.

My friends in the humanities laugh at me for thinking that this is a big discovery. But it came as a shock to economists to be told that they were poets and novelists, like the physicists and historians. Not that the economists changed their ways after the shock. Following the understandable conservatism of science, they tried not to listen, and mainly succeeded.

In studying the humanities from the 1980s onwards, I came to see economics as needing breadth of a sort it has lost during the past century or so. Economists need to study language as well as prices, ethics as well as statistics, ends as well as means, history as well as the latest news. In a word, in the title of my upcoming book, they need that “humanomics”.

Taylor: You have long championed capitalism and its possibilities; what kind of capitalism do you think is needed for our current times?

McCloskey: Let’s get ‘capitalism’ straight. The word is exceptionally silly, a scientific error compressed into a poison pill, because it directs attention to the ▶

Deirdre McCloskey is Emerita Distinguished Professor of Economics, History, English and Communications at the University of Illinois at Chicago. A prolific writer, her latest book, *The Myth of the Entrepreneurial State*, co-written with Alberto Mingardi, is out now. Her forthcoming book is *Bettering Humanomics*





“I came to see economics as needing breadth of a sort it has lost during the past century or so”

accumulation of capital as what made us rich and liberated. No, it did not. What made us rich was being (at first only a little) liberated, leading after 1800 to an explosion of innovation, accelerating in the next two centuries. The result was a 3,000% rise in the real incomes per person of the poorest among us. A nascent liberalism in north-western Europe, and at length in a good deal of the world, gave ordinary people permission to have a go. And go they did.

A better word than capitalism is ‘innovism’. It reorients economics to studying the conditions for human creativity. The conditions are not top-down coercing of people but liberty. Would you favour top-down coercion in painting or music or science or fashion? I thought not. So why in the economy?

Taylor: Have the unprecedented threats we face in many areas – Covid-19, climate change and rising populism – changed your thinking about capitalism in its current form and our best route to recovery?

McCloskey: The real threats we face today are two: tyranny, which denies liberalism; and poverty, which tyranny causes. After dealing with tyranny and its evil fruit, the rest can follow; dealing for example with global warming (humanly caused and humanly solvable), or with the alleged rise of inequality (which in fact is falling in the world like a stone). Authoritarian populism of the Trump-and-Putin sort

leads backwards, away from liberalism. There is no other good future for humans but a generous and respectful liberalism.

Taylor: The pandemic has resulted in calls for further state intervention and, at present, governments worldwide have indeed taken a greater role.

McCloskey: It’s like a forest fire, which we liberals believe the state should fight quickly, as South Korea and New Zealand did. Alas, the UK and the US did not, and now they are in flames. But it does not mean the state should take over the economy permanently. Labour’s Clause IV has been well tried, not to speak of the USSR or Venezuela, and has not worked.

Taylor: There is mounting evidence that the impacts of climate change are with us already.

McCloskey: Yes: look at the literal forest fires on the west coast of the US earlier this year. But a liberal economist says, ‘be prudent’. (Actually, any economist says that: it is what we are hired to say.) ‘Don’t do foolish things, like closing down industrial civilisation. The threat is not existential, despite what Swedish schoolgirls believe. Listen to Danish engineers instead.’

Taylor: Do these factors change the role that we need the state to play?

McCloskey: No. We must be wary of throwing away our creative liberties in exchange for a masterful man on a white horse, or even a Sir Humphrey Appleby GCB KBE MVO in a white hall. H. L. Mencken noted that “the whole aim of practical politics is to keep the populace alarmed (and hence clamorous to be led to safety) by menacing it with an endless series of hobgoblins, all of them imaginary.” Another word for liberalism might be ‘adultism’. We should not treat adults like terrified children.

Taylor: Could you say a bit about your latest book?

McCloskey: This is a short book I wrote with Alberto Mingardi, *The Myth of the Entrepreneurial State*. It takes aim at the utopian tyranny recommended by, among others, the economist Mariana Mazzucato. She believes in statism, the Keynesian idea that we wise economists can run the economy from above. Mingardi and I doubt it.

Taylor: You have talked about the need to reclaim the word liberal, which you argue has been under assault from the centre left and right. Could you go into more detail about how you believe liberalism has been distorted from its true meaning?

McCloskey: Let’s get ‘liberalism’ straight. In the tradition of Voltaire and Adam Smith and Mary Wollstonecraft it means a society with equality of permissions, with no physical coercion to slavery: no serfs to lords, citizens to kings, wives to husbands. It is deeply egalitarian, which in 1776 was a shocking notion, and has been only slowly and partially realised since then.

The word ‘liberalism’ started to morph into its opposite in a New Liberalism initiated by the Oxford philosopher T.H. Green in 1881. Instead of a permission not to be coerced, it became in the Liberal Party, in US Progressivism, and in various socialisms and fascisms, a “capacity of doing something worth doing”, as Green put it. But we already have words for such a capacity: power, health, intelligence and, above all, wealth.

Green started off on the road to the economist Amartya Sen’s confusion of capabilities with liberty. We arrive at a limitless justification for coercing Peter to give to Paula. The outcome is the modern state, seizing for its fine purposes a third to a half of what its citizens make. Liberalism was a new permission to have a go in art and science and business that made us rich and liberated. Now it’s two centuries old and under attack by armed utopians, but still the best life for humans.

Taylor: You have said that liberalism is grounded in equality. At a time of greater inequality than at any other point in living memory, what does this mean for the future of liberalism?

McCloskey: It is quite false, actually, though repeated endlessly, that we are in a time of inequality. I have written at some length on the matter in *Why Liberalism Works*, but to give a desperate summary: world inequality is at the lowest point since 1800, when the average Briton was earning about £3 a day (expressed in modern prices); now she earns about £90 a day in the same terms. The rise dwarfs any redistribution. The cant about inequality is startlingly poorly founded.

But the trouble is that people believe that things today are rotten in all kinds of ways, and that is indeed a great threat to liberalism. People have to accept an ideology of adult self-respect and respect for others, and to resist the childish sin of envy, in order to avoid descending into populisms of left or right.

Taylor: What would a more liberal approach mean for how we think about and practise economics?

McCloskey: See humanomics. Liberalism is a foundational discipline for all the modern sciences, natural or social or humanistic. It’s not an accident that science has flourished most in the more liberal societies, from ancient Athens to the modern UK and US. The anti-ethical, positivist, neobehaviourist and illiberal movements over the past decades in economics, which I skewer in my upcoming book, don’t fit the bill for an ethical and persuasive economics for a free people.

Taylor: You have described Trump as a sociopath. If he wins a second term, what will this mean for US economics and liberalism?

McCloskey: “A lazy, ignorant, narcissistic sociopath”, actually. If by the time this is published, Trump has won, I will have applied for Irish citizenship. But it will lack point, because liberalism worldwide will collapse. The tyrants will have won. We will have decades of darkness until the obvious and natural system for beings descended from bands of egalitarian hunter-gatherers will be able to reestablish itself. If, *deo volente*, he has lost, the opposite will happen. The success that Putin had in getting his Manchurian candidate into the White House will come to naught. The encouragement to tyranny that Trump’s term brought across the globe will reverse. Hallelujah, hallelujah, liberty has risen indeed. ■

ACCESS ALL AREAS

Policymakers need to pay more attention to the voices of those with disabilities

by Saba Salman

🐦 @Saba_Salman

Debates about Covid-19 recovery and economic renewal ignore disabled people. This is shameful given that even before the virus, the UK's 7.7 million working-age disabled people already faced significant inequalities. Government figures for April to June 2020 show the employment rate for disabled people was 53.6%, compared with a rate of 81.7% for non-disabled people. Less than 6% of learning-disabled people are in paid work.

Despite equality laws and a Conservative Party pledge to reduce the disability employment gap, the gap persists (albeit slightly improved on last year). The government's national recovery strategy states that it "will ensure people with disabilities can have independent lives and are not marginalised" and "their overall health outcomes do not suffer disproportionately". But the current response is inadequate. Chancellor Rishi Sunak's Plan for Jobs policy aimed at boosting recovery refers to disability once. The Job Support Scheme subsidising salaries for employees who now work fewer hours is welcome, but it contains nothing specifically for disabled people.

Further pressures

Since austerity measures kicked in after the financial crisis, eligibility criteria for support have tightened. From 2013, the introduction of Personal Independence Payment (PIP) has been dogged by delays and lost payments. And – as research from Disability Rights UK shows – in the workplace existing challenges include inaccessible offices, a lack of disability awareness and

a reluctance among employers to spend money on modifying equipment for disabled staff.

Covid-19 exacerbates existing barriers to economic inclusion for disabled people. Almost two-thirds of all those who have died from the virus in the UK are disabled, according to the Office for National Statistics. Figures from health and social care regulator the Care Quality Commission show a 175% increase in unexpected deaths among learning-disabled or autistic people during the pandemic. Even before Covid-19, people within this part of our population died an average of 15–20 years earlier than others because of poorer healthcare, according to the NHS-commissioned *Learning Disability Mortality Review*.

What is missing is a focus on the economic benefit of employment support for those stereotypically seen as less productive. In 2010, a landmark study on supported employment (where dedicated support staff enable disabled people into work) for Kent County Council suggested that, for every learning-disabled person helped into a job, the council reaped an average annual saving of £1,300.

What is now needed are schemes like Surviving Through Story, an Open University-backed project sharing the views of autistic or learning-disabled people, creating a national record of Covid-19's impact. The voices of support staff are equally crucial. Social care training organisation Paradigm surveyed 120 support workers (staff who help people in their own homes) around the UK about their experiences. Almost 85% said their biggest concern was that

Saba Salman is an author and journalist and chairs the charity Sibs, which supports disabled people's siblings. Her book *Made Possible: Stories of Success by People With Learning Disabilities – In Their Own Words* is out now with Unbound



the people they support would contract Covid-19. These findings reflect the widespread frustration of a workforce bypassed in terms of recognition and investment during the pandemic.

Grassroots solutions

The national recovery plan should include a fully inclusive vision for employment. In the absence of a government plan, disability charity Leonard Cheshire has published its own. This argues for more support to help disabled people to find jobs and the introduction of a single labour market enforcement body for employment rights, as proposed by the RSA's Chief Executive in his review of modern working practices.

Alongside this, it is vital to unpick the assumption that earning a wage will negatively affect welfare support. This is often a perceived rather than a real fear, based on a lack of information or incorrect advice. The government's 'permitted work' rules mean certain benefits (like PIP, which is not means-tested) can still be claimed when earning a wage.

Oxford-based charity My Life My Choice (MLMC), which is run by and for disabled people, employs learning-disabled people as consultants. They deliver disability awareness training and can earn £500 a month without this affecting their benefits. Leeds-based human rights charity CHANGE has a 'co-worker employment' model where non-disabled staff support disabled colleagues.

During lockdown, healthcare services were focused on Covid-19 patients. Once the national lockdown

was lifted, the public were encouraged to start seeking medical help for non-Covid-related issues again (although at the time of writing, with lockdowns looming once more, it could be that this advice again changes). However, this message has not been targeted towards disabled people, many of whom already experience physical or communication barriers to using public services. In response, Oxford's MLMC has created regular mailouts with 'easy read' advice encouraging disabled people to use services again. The charity has also arranged meetings with local health and care commissioners to discuss issues such as what services people miss and how easy it is to see a GP.

Giving everyone a voice

These are the kinds of innovations, perspectives and practices that national policymakers should embrace, encourage, learn from and share publicly if we are to discover what everyone in our society needs as we respond to Covid-19.

The current response to the pandemic overlooks the very people it has hit the hardest. There is a clear moral argument for ensuring our economy and public services are inclusive. But aside from the ethical imperative, there is a practical reason for everyone to play a part as we try to cope. Supporting all our citizens means people are less likely to be pushed to a crisis point demanding emergency health or social care. The question is not why or how we should include disabled people in debates on Covid-19 recovery, it is why not? ■

A NEW SOLIDARITY?

Is the EU's response to the Covid-19 pandemic a federalist leap or a one-off crisis response?

by Zsolt Darvas
🐦 @zsoltdarvas

Amid the devastating human and economic toll caused by the Covid-19 pandemic, for the first time in history, EU nations agreed to a sizeable fund – to be financed by jointly guaranteed borrowing – to finance expenditures throughout the bloc. The plan, which is yet to be ratified, was received positively in many different corners. But will the pandemic recovery fund be able to support Europe's recovery and reduce social inequalities? Will it be a major step towards federalist integration?

Before addressing these questions, let me take a step back to highlight some fundamental tensions within the EU, the differentiated impact of the pandemic on European nations and the various initiatives aimed at fostering solidarity within the EU.

Social inequalities in the EU

Most EU countries have generous welfare systems, income inequalities within EU countries are much lower than in the US and most developing countries, and poverty, as measured by the World Bank, is very low. Yet for those Europeans who live in poor conditions, face job insecurity, suffer from unmet medical needs or feel lack of opportunity, it is little solace that the situation is worse elsewhere in the world.

A particular worry is countries falling behind economically and socially. Italy, for example, had the same level of per capita income as Germany in the

early 1990s (measured at purchasing power parity, which adjusts incomes for price level differentials). Now Italy is 25% lower. When adjusting for inflation, all main segments of Italian society suffered from income declines from the mid-2000s to the mid-2010s, with low earners suffering more than high earners. The youth unemployment rate is around a third, and the share of early school leavers is 14%, the fifth worst value in the EU. It is not surprising that Italian voters expressed their dissatisfaction by voting for populist and more politically extreme parties in recent elections.

But there are success stories too. Ireland was well below the EU average in the early 1990s and is now the second-richest country in the bloc, after Luxembourg, in terms of per capita income. Central European nations that joined the EU in 2004–2013 have shown impressive convergence in the past 25 years.

Political spats

Still, anti-EU sentiment has been on the rise both in Italy and in many central European countries for some time, as reflected by the election of governments that have clashed with EU institutions. Disagreement on immigration policies is a common theme, topped by fiscal woes in Italy and rule of law concerns in some central European countries. Certain foreign policy issues, in particular the attitude towards Russia, are another sticking point. ▶

Zsolt Darvas is a Senior Fellow at Bruegel, a European thinktank that specialises in economics, and Senior Research Fellow at Corvinus University of Budapest





“The EU’s ability to offer solidarity is constrained by its institutional set-up”

The views on the desirable course of action over these subjects differ so much across member states that it is almost impossible to find a common solution. Existing rule of law procedures will not lead to anything, given that allies will veto one another’s punishment. Thus, in a number of important areas that are at the heart of fundamental EU values, EU cooperation mechanisms hardly work. This does not preclude successful cooperation in other areas, yet the mistrust resulting from fundamental disagreements makes it harder to find common ground.

The differentiated pandemic hit

Naturally, the severity of lockdown measures, as well as the importance of tourism (a sector particularly badly hit by lockdowns) to a country’s economy correlate with economic distress. But there are two additional important factors.

The first is the ability of national fiscal policy to contain the economic fallout from the pandemic. Thanks to the suspension of European fiscal rules in March and the relaxation of European state aid rules in the same month, EU member states were able to provide fiscal stimulus packages. But such ability differs: calculations by Bruegel show that countries with weaker public finances, such as Italy and Spain, provided significantly fewer immediate fiscal support measures than countries with healthier fiscal accounts, such as Germany and Denmark.

The second factor is the quality of governance, as revealed by the econometric estimates of André Sapir, using World Bank governance indicators. He conjectures that the governance indicator could reflect the quality of behaviour of both private and public economic agents, and thus countries with weaker indicator scores might have suffered from weaker responses, amplifying the adverse economic effects.

Beyond country differences, different socio-economic groups were also hit to varying degrees.

IMF research finds that epidemics raise income inequality, reduce the share of incomes going to the poorer segments of society and lower the employment-to-population ratio for those with basic education but not for those with advanced degrees. The authors warn that Covid-19 could raise inequality too, and recent data suggests that this is the case. From the last quarter of 2019 to the second quarter of 2020, the number of jobs occupied by low-educated workers (lower secondary and below) declined by 7% in the EU, while jobs for tertiary-educated workers expanded by 3%. Elementary occupations saw a 10% drop, the number of service and sales workers fell by 8%, and plant and machine operators and assemblers declined by 5%. In contrast, professionals gained 4%.

The ability to work remotely online greatly influences labour market outcomes, as research by the US Bureau of Labor Statistics shows. About 70% of those who completed university studies are able to

work from home, compared with about 15% who have not completed secondary school. As regards occupations, two-thirds of professionals and 85% of management can work from home, in contrast to close to zero for workers in transportation, installation, construction and agriculture.

Thus, better-educated and higher-income earners have a much greater ability to telework and are much less prone to job losses than lower-educated and poorer colleagues. Consequently, the Covid-19 pandemic has further increased social disparities between the poor and the rich even in Europe, where governments put in place massive employment protection programmes.

The different fiscal capacity of member states, as well as differences in their quality of governance, raises further questions about EU-wide solidarity.

Initial pandemic solidarity measures

The EU's ability to offer solidarity is constrained by its institutional set-up. Ultimately, what it can provide depends on member states' will. The EU, as a legal entity, does not have any tax-raising ability, and any EU financial resources have to be approved unanimously by the 27 member states.

Still, the European Commission quickly recognised the severity of Covid-19 and played important supporting and coordinating roles starting in February, in areas such as public health, travel, transportation, vaccine research and digital solutions. While the Commission does not have any new financial resources, it proposed a number of changes to the existing EU budget, such as to mobilise all unused funds, allow reallocations between and within programmes, simplify access criteria, provide liquidity by delaying the repayment of unspent pre-financing and abolish national co-financing of EU cohesion spending. In addition, the suspension of fiscal rules and relaxation of state aid rules were crucial in allowing EU governments to introduce fiscal packages aimed at containing the public health, social and economic fallout from the coronavirus.

Arguably, while these measures were helpful, the first big splash came from the European Central Bank (ECB), albeit as a damage limitation attempt after its President, Christine Lagarde, pushed Italian and other euro-periphery yields to the sky on 12 March by saying "we are not here to close spreads", referring to the differences in borrowing costs of euro area governments. Over the following days, an intense communication effort tried to calm the situation, but ultimately the 18 March announcement of the €750bn Pandemic Emergency Purchase Programme (which in June was expanded to €1,350bn) brought calamity to euro area government bond markets. The

ECB also relaxed bank capital rules, offered credit to banks with a subsidy, and accepted a broader range of assets and less creditworthy assets as collateral from banks. These measures contributed to financial stability in the euro area and beyond and lowered government bond yields, which helped member states to implement their fiscal stimulus measures. Thus, similar to the 2012 euro crisis, the ECB took decisive measures relatively early on, underlying its central role in European crisis management.

The March–April gatherings of European finance ministers led to feeble results, despite their praising their own actions as comprehensive. Three concrete common financial instruments were decided. One was the ministers' endorsement of the Commission's proposal for a new employment-support facility called SURE (the temporary Support to mitigate Unemployment Risks in an Emergency), which offers cheap loans to member states up to €100bn. So far, 18 countries, including some EU-sceptic countries like Hungary and Poland, have applied for €90bn of loans in total, suggesting that this instrument is broadly appreciated. The second instrument is a €240bn pandemic credit line from the European Stability Mechanism (ESM), the eurozone's rescue fund, to cover pandemic-related healthcare costs. No country has applied for it in the past half year, and my bet is there will be no application for it in the future either. This is because the ESM is a rescue fund and a loan from it could signal that the requesting country has weak public finances. The third financial instrument is a €200bn extra liquidity boost to the European Investment Bank's capacity to support hard-hit small and medium-sized enterprises in the EU. While useful, this instrument is not a game changer.

Justifying an EU-wide recovery fund

An oft-repeated phrase is that a monetary union is not sustainable without a fiscal union. In my view, this claim is too simplistic. Let's consider the justification for financial solidarity in the current pandemic.

Clearly, countries with low public debt, such as Germany and the Netherlands, do not need any fiscal support from a centralised fiscal capacity. France, the second-largest country in the EU, has a considerably higher level of public debt than Germany, yet France does not need any fiscal help from its neighbours. Central European euro members, such as Slovakia and the three Baltic countries, have healthy public finances and good growth prospects, so these countries could also easily weather a fiscal storm. The very reason a eurozone-wide, or an EU-wide, fiscal support is needed is that some countries in southern Europe, most notably Italy, Spain, Greece and Portugal, have high

public debt and low fiscal space to support their own economies. The growth outlook of these countries is not so bright either. Their unemployment rates were well above the EU average even before the pandemic, their social disparities are wider than elsewhere in Europe, and their government effectiveness and corruption control are weaker.

These countries will struggle under the financial burden resulting from the pandemic-related economic collapse. If left alone, their economies would become further depressed, for a longer period, escalating already widespread social inequalities. The popularity of anti-EU political parties could strengthen, further hindering the smooth functioning of the EU.

Several EU members faced fiscal tensions after the 2008 global financial crisis and subsequent euro crisis, which primarily resulted from unsustainable fiscal, credit and external debt positions. That time, eight EU countries received financial assistance loans with strict conditionality. The Greek programme was particularly problematic, as it was based on overly optimistic assumptions, required very large fiscal consolidation at a time of drastic economic contraction, and the detailed conditionality was intrusive. In most countries

obtaining financial assistance, GDP and employment fell more than planned, while poverty increased. These experiences made EU financial assistance unpopular.

The Covid-19 public health crisis and consequent economic collapse is a completely different situation. The pandemic is an extraordinary external shock causing human suffering in a way unseen since the Second World War. Article 3 of the Treaty on European Union includes the objective of promoting economic, social and territorial cohesion and solidarity between member states. When, if not now, should this prevail?

It is also in the self-interest of countries with healthier fundamentals to offer help. The serious economic and social decline of southern European member states will also adversely affect northern members. The risk of a massive sovereign debt crisis, as well as a eurozone breakup, would increase, with dire consequences throughout the EU.

I am sure Angela Merkel and Emmanuel Macron recognised these risks and their responsibility to act when on 18 May they called for a recovery fund which would redistribute €500bn among member states to help “the most affected sectors and regions”, financed by borrowing on markets on behalf of the EU. This was an unprecedented proposal in the EU’s history. Within a week, a counter-proposal came from the so-called ‘frugal four’ countries: Austria, Denmark, the Netherlands and Sweden. They essentially called for a substantial reshuffle of current EU spending, which includes even more money than the proposed recovery fund. They also called for a temporary recovery fund that only provides loans and avoids any mutualisation of debt. The Franco-German proposal and the frugal counter-proposal highlight the starkly opposing views on European solidarity among member states.

On 27 May, the European Commission quickly followed up with a comprehensive proposal, including a recovery fund named Next Generation EU (NGEU), involving €500bn expenditures and €250bn loans. Subsequent negotiations lowered the expenditure component to €390bn and increased the loan component to €360bn, and this was approved by the European Council on 21 July. The EU will borrow to finance the expenditures and the loans, with all member states guaranteeing this borrowing.

Looking ahead

NGEU has had positive effects already, by boosting confidence and sentiment around the actions the EU is prepared to take to protect its populace. The borrowing costs of Italy and Spain have fallen, and a recent EU bond issuance was oversubscribed 13 times. The risk of a euro area breakup has receded. However, a number of questions loom over the process.

RSA Fellowship in action

Inclusive Entrepreneurs

Jacqueline Winstanley FRSA set up The Inclusive Entrepreneur Network in 2013 to provide support for entrepreneurs with protected characteristics, particularly those with disabilities. “It’s about helping people to understand the need to navigate their health and wellbeing while being an entrepreneur, rather than the other way round,” she explains. When the Covid-19 pandemic broke out, many of the network’s members struggled with isolation and the economic impact of lockdown.

Unable to organise face-to-face meetings any more, Jacqueline realised that developing an online programme and resources would help to create a sense of community and could be a way of sharing important information. Awarded a £2,000 RSA Catalyst Seed Grant, Universal Inclusion has used the money to create a series of 10 podcasts, recorded over the course of the lockdown and now available online. It also held a weekly briefing, giving people the chance to share thoughts and experiences. “Inclusive entrepreneurship isn’t just about turnover, it’s about social and different kinds of economic impact,” Jacqueline says. “An inclusive self-employed sector is resilient and can help to share good practice, particularly at times like this.”

■ To find out more, contact Jacqueline at universal.inclusion@icloud.com. You can listen to the podcast at <https://www.universalinclusion.co.uk/about/podcasts>

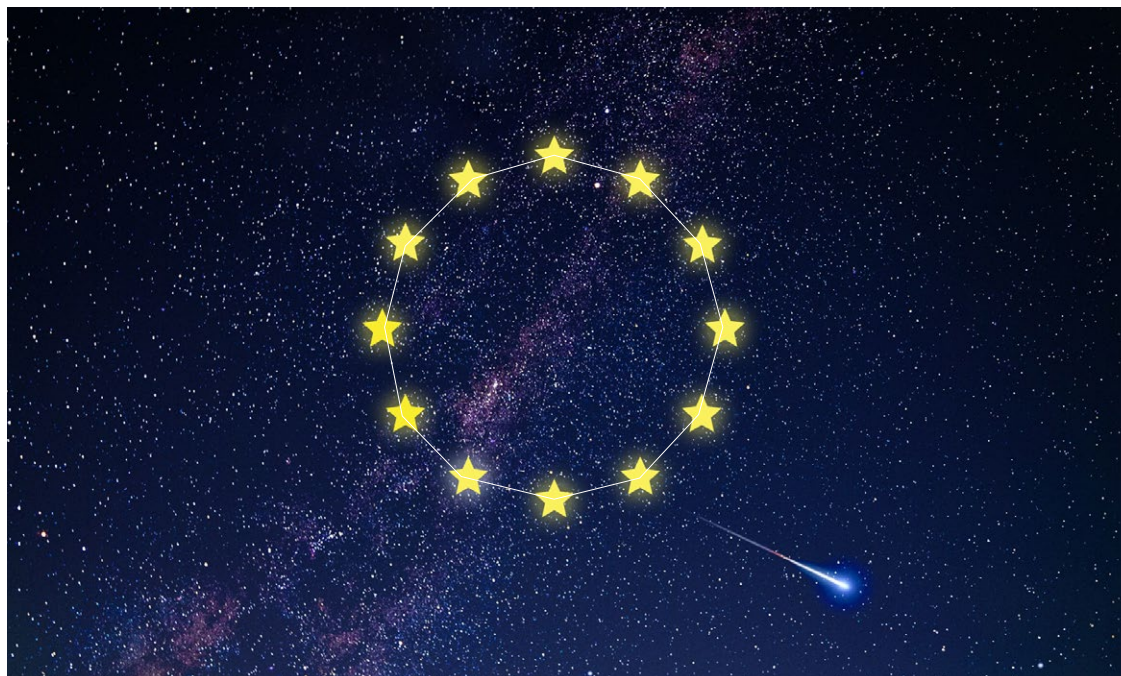

First, is NGEU big enough? No. Italy would be likely to obtain about 5% of its annual GDP (distributed over six years), while Spain would get about 7%. These are large amounts and can make a difference, but in themselves these sums will not materially change the public debt profile of these countries. To reduce the debt burden, policies fostering growth are needed.

Second, will NGEU reduce social disparities within the EU? Yes and no. Yes, because it will likely narrow economic divergence between countries. But it is hard to see how NGEU spending, which should focus on green transition and digitalisation, will address longstanding social disparities within countries, which were further exacerbated by the pandemic.

Third, will NGEU bonds contribute to capital market developments? Yes. The EU is set to become the greatest supranational bond issuer. EU bonds could become a reference asset for financial markets, which would be a benefit on its own. For this reason, but also because repayment of EU debt would necessitate national taxpayer money, members might decide to roll over maturing EU debt, like national governments roll over their maturing debt.

Finally, will NGEU plant the seeds of deeper EU fiscal integration? Unlikely. The debate leading to the adoption of the package revealed deep-rooted disagreements. Ultimately, all 27 member states agreed to the package. But the frugal four agreed only because of the extraordinary human and economic toll, and they obtained larger EU budget rebates as well as some control mechanisms. One such mechanism is

a ‘red card’ procedure, whereby any country could raise concerns about NGEU spending in any other country. The other is a yet-to-be-agreed rule of law procedure, which could lead to suspension of EU funds in case of rule of law deficiencies. While such control mechanisms can be helpful in ensuring better spending of EU money, they also have the potential to generate endless disputes between member states, undermining possible new EU-wide instruments.

At the time of writing, Hungary and Poland had put a veto on the EU budget deal, including the recovery fund, because of their disagreement with the rule of law procedure. We do not know if there will be a compromise, or if both sides will remain firm. The latter option would lead to a deep political crisis, unless voters in Hungary and Poland decide on new governments with a more cooperative attitude. Unanimity requirements do not make the prospect of reforming EU decision-making bright. In a deepening political crisis, the recovery fund could be set up as an intergovernmental agreement between the willing 25 member states.

Nevertheless, let me close with an optimistic observation. The various instruments proposed by the Franco-German duo, the European Commission and the ECB demonstrate that, when the EU faces an extraordinary shock, member states are able to put aside their day-to-day disputes and find common solutions fostering solidarity. There is hope for common solutions when the next crisis comes – at least for the coalition of the willing. ■

ROOT OF THE MATTER

The inequities highlighted by Covid-19 have deep-seated historical origins

by Anne Price
 @AnnePriceICCED

The Covid-19 crisis has exposed and exacerbated inequity across the world, as shown in the widening economic and health disparities across race, gender, geography and class lines. In the US, it is probable that the (already significant) racial wealth gap has further expanded in nearly immeasurable ways. Pre-existing structural inequalities are the root cause of Covid-19's unequal end result.

Inequality is not an accident

Black people have never been able to fully realise the power and freedom that wealth bestows. Throughout US history, Black people have been systematically denied the ability to build, maintain and generate wealth. As a result, they have among the lowest wealth holdings of any other racial and ethnic group in the nation. This is especially troubling during an inevitable recession, when the disproportionate economic consequences of having low wealth holdings, including the (in)ability to endure the Covid-19 economic crash, will become all too clear. Not only are Black people facing more job losses than white workers, but they tend to have less to fall back on.

According to the 2019 Survey of Consumer Finances, the typical Black household holds \$24,100 (about £18,660) in wealth. White households, in comparison, own nearly eight times as much, at \$188,200 (£145,714). According to research from

the Brookings Institution, the ratio of white to Black household wealth is higher today than it was at the beginning of the century. Research carried out by the Insight Center shows this enormous disparity is not explained by income level, level of education, rate of return on investment or family background.

The racist roots of today's inequality

One of America's most enduring myths is that slavery was incompatible with capitalism. However, it is now clear that the US slave system formed the basis of both the entire national economy and capitalism as we know it today. The process of commoditising Black people was not only America's first big business, providing the pathway for the country to gain outsized power and wealth, but the nation's subsequent history and current discriminatory practices were also made possible as an extension of this inhumane dynamic.

Until the Civil War, nearly all cotton used in industrial production was grown by enslaved Black people in the South. The returns of monopolised cotton created wealth not just for Southern plantation owners but also for merchants, bankers and insurance companies in the North.

Slavery also facilitated a number of financial innovations and modern-day business concepts, including vertical integration and start-up costs. White men, for example, used enslaved Black people ▶

Anne Price is the President of the Insight Center for Community Economic Development and a Fellow at the Roosevelt Institute. Her work focuses on racial and gender wealth inequality



to develop new ways of depreciation. Bondsmen used enslaved Black people as collateral, and they were sold to bondholders to generate wealth. Enslaved Black migrants became a legal form of property that could be used to pay off debts and served as a source of local and state tax revenue.

Today's shareholder primacy is also rooted in slavery. Cotton slavery was constantly being reorganised in order to maximise profits. To increase production, slaveowners experimented with labour control, establishing quotas and using forms of torture and violence. In 1862, the average Black enslaved fieldworker picked 400% more cotton than their counterpart did in 1801. If hard work alone were the basis of wealth, then Black people today would be the wealthiest people in the United States.

Government-backed inequality

The ability to accumulate wealth in the US has nothing to do with individual behaviour or personal responsibility but with the longstanding political and policy choice to build exclusionary systems and institutions. One way to better understand racial inequity and how Black people specifically have been systemically blocked from wealth-building is by exploring government programmes that excluded them.

Throughout US history, white Americans have been given gifts of land, government-backed mortgages and farm loans, a social safety net and business subsidies, often exclusively. Notably, many historical government programmes not only excluded Black

people but were also rooted in racist stereotypes about them that caused long-term damage that hinders the Black community to this day.

The 1862 Homestead Act, for example, is often cited as a model government-backed asset-building programme, but that story is only true for white people. In reality, it was an asset-*theft* programme. The Act expropriated land from 42 Indigenous tribes and redistributed it to white homesteaders who received 160 acres of land for free if they agreed to pay a small fee and farm it for five years. According to historian Keri Leigh Merritt, “The Homestead Acts were unquestionably the most extensive, radical, redistributive governmental policy in US history. The number of adult descendants of the original Homestead Act recipients living in the year 2000 was estimated to be around 46 million people.” She continues: “If that many white Americans can trace their legacy of wealth and property ownership to a single entitlement programme, then the perpetuation of [B]lack poverty must also be linked to national policy.”

Perhaps no other federal agency has had a more pervasive and powerful impact on the inability of Black people to build generational wealth than the Federal Housing Administration (FHA). The entire FHA appraisal process was based on the idea that racial segregation was necessary to ensure the maintenance of property values. This essentially created white-dominated suburbs, while Black people paid more for property than their white counterparts; that is, if they were even able to purchase a home at all. Between 1934 and 1962, the federal government

backed \$120bn in home loans; more than 98% went to white people. Between 1946 and 1960, over 350,000 homes in northern California were constructed through FHA financing, but fewer than 100 homes went to Black families. If homeownership is such a fundamental aspect of the American dream, then Black people never had a chance.

Historical inequality today

As the economy takes a downturn in the aftermath of the pandemic, white households and families in the US are better able to withstand these trying economic times than others. There are early warning signs that Black people are more likely to struggle in meeting monthly expenses due to joblessness or drastic reductions in income, and thus face the possibility of significant wealth loss. Today, joblessness among Black people is 16.8%. Seven months into the pandemic, Black people had recovered just over a third of jobs they lost, compared with over half for white Americans.

When it comes to keeping a roof over their heads, the struggle for Americans is unequal. According to Harvard University's Joint Center for Housing Studies, among Black people who are renting and have lost employment income since mid-March, more than a third – 35% – deferred or were late with their rent payment in May. An analysis by the Urban Institute of the Census Bureau's Pulse Survey meanwhile showed that in the same month 28% of Black people who own their homes did not pay or deferred their mortgage payment, compared with just 9% of white homeowners. A survey conducted by the Global Strategy Group from April to May of 500 Black and Latinx business owners found that only 12% reported having received the federal aid they applied for from the Paycheck Protection Program, and nearly half feared they would permanently foreclose within six months. Further, after states mandated social distancing during the pandemic, an estimated 41% of Black-owned businesses closed in just a month, reports the National Bureau of Economic Research.

The pandemic has exposed how decades of discriminatory policymaking and pervasive structural racism are baked into America's housing, labour market and healthcare systems. Black people living in neighbourhoods that were redlined (a government practice in which minorities were excluded from living in certain neighbourhoods) over 80 years ago are at a higher risk of severe illness or death from Covid-19 today. A segregated labour market has disproportionately sorted Black working people into jobs that are often excluded from federal protections based on policies extending as far back as the New

Deal. Many of these occupations are at the greatest risk of exposure to Covid-19 and also to layoffs. In New Orleans, for example, Black people constitute 79% of all cooks, 87% of hairdressers and 84% of home health aides, but only 60% of the population.

Normal was never enough

Society cannot afford to go back to 'business as usual' in the US or in any country suffering from the past 50 years of flawed-and-failed economic ideology. Economic and wealth disparities are not the cause of inequality in the US; they are a measurement. Structural inequity – in the workplace, in the economy and throughout society – is inherent to how America functions, and the only way to a better world is by building intentional, explicit inclusion. There are several ways we can do this. First, we must dismantle systems of oppression and wealth extraction. Wealth accumulation and extraction are a result of structural forces that are interconnected and deeply tied to historical policies. For Black people, accumulating wealth has become an insidious game of whack-a-mole; as soon as they fight to remove one barrier to building wealth, another one springs up. Second, we must erase dominant narratives that provide a rationale for disinvesting in Black people and their communities, and write a new story with an intentional focus on countering anti-blackness. Finally, we must support a transformative, structural approach to building wealth among Black people with significant capital investments and by centering advocacy, legal changes and movement-building efforts.

Building the wealth and health of Black women should be a primary goal. "Black women best" is an economic principle that is gaining momentum in the progressive policy space. Coined by Janelle Jones, Managing Director for Policy and Research at the Groundwork Collaborative, the framework argues that if Black women – the most disadvantaged, excluded and exploited group in the US – are able to not only get by but actually thrive in the economy, then it must finally be serving the basic needs of everyone and providing equitable economic opportunity.

Today's economy was built by excluding Black people and prioritising the wealth of white individuals, families and businesses. This was true long before Covid-19 rocked us economically. If we begin directing policy towards Black women and centering their lived experience, we can start to right size the unequal (and racist and sexist) economic systems that prevent Black women and people of colour from building wealth. In the end, this is what will produce a society that works for all Americans. ■

WINNER TAKES ALL

As global companies accumulate ever more power, are competition laws no longer fit for purpose?

by Michelle Meagher
 @MichMeagher

We like to think of business as a static machine: inputs go in, products come out. As sustainability moves up the business agenda, the question has become ‘what is the purpose of this machine and how can it be made more responsible?’ Efforts towards reform have prioritised transparency and reporting. Regulators have also encouraged company management to voluntarily take into account how their machine impacts all stakeholders, not just shareholders. Investors are piling in to support the most stakeholder-friendly companies.

Unfortunately, these efforts at cajoling business into social responsibility have fallen short. This is partly because we are fixed on the wrong metaphor. Business is not a static machine. It is not a magic productivity box. Business is a combine harvester. It sucks in land, capital and people and churns up the world as it goes. The stock market is not just a tally of value; it is a map of how much physical and social space corporations have colonised.

Two things become clear with this paradigm shift: it matters in which direction we point these machines, and it matters how powerful we let them become.

A turbo-charged machine

The combine harvesters will not slow down voluntarily; they are built to churn, and technology has only sped things up. The law, which is meant to provide guardrails circumscribing the machines’ scope of movement, has also stepped out of the way. Limited liability absolves those driving the machines from financial accountability. The principle of shareholder value maximisation and the practice of quarterly

reporting force directors to put the pedal to the metal, and executive remuneration that ties pay to share price rewards them handsomely for doing so. Competition law – the law that governs how companies compete in the market, how they may exert their power, and how and when they may join forces – has facilitated the steady concentration of markets, channelling power towards a few companies in each industry. From Big Tech to Big Food, the combines have been getting bigger and bigger, and more and more powerful. In the UK, for example, 70% of the groceries market is controlled by just four supermarkets, with Amazon coming up fast.

These global monopolies that distort competition have been created with regulatory permission, ironically in the name of ‘free market’ capitalism. Mergers are approved and monopolies tolerated under the aegis of efficiency. But this again is the view of business as a static machine. If we recognise business as a combine harvester, we see that allowing companies to accumulate power actually supercharges the machine as it shapes the real world with ever-greater disregard for those in its path. ‘Innovation’ is relied upon as a fig leaf, used as a get-out-of-jail-free card to justify monopolised industries. In reality, not all innovation is good. Credit default swaps are a sort of innovation, and they brought the financial system to its knees. Fracking and opioids are innovations. It surely matters what kind of innovation we are talking about. We must not lose sight of this.

Competition law is currently being used to protect a narrow set of public interests that, in reality, are aligned to the needs of the combine harvesters. The technical ▶

Michelle Meagher is a business and competition lawyer, a Senior Policy Fellow at the UCL Centre for Law, Economics and Society, and co-founder of the Inclusive Competition Forum. Her book, *Competition is Killing Us*, is out now

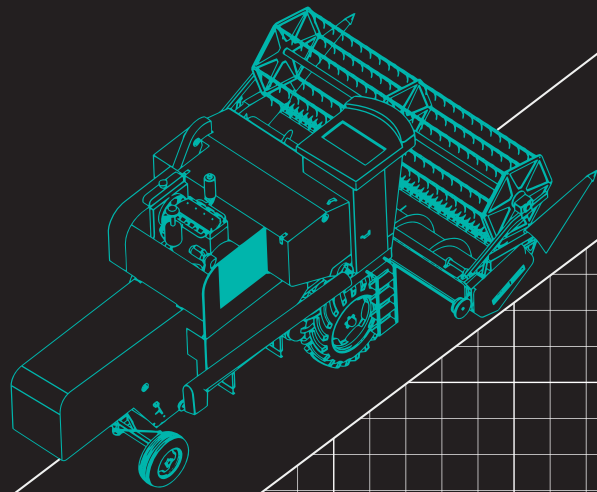

standard within competition law that is applied to parse good competition from bad is ‘consumer welfare’, with the ultimate test being whether the business conduct in question will result in lower prices for consumers and thus be deemed pro-competitive, regardless of how monopolised the resulting market is. Thus, over the past few years, a string of mergers in the agribusiness sector were approved worldwide, taking the Big Six down to the Big Four, and leaving farmers facing enormously powerful companies dictating every aspect of planting and cultivation, with serious implications for global biodiversity.

This logic that focuses only on consumer prices is flawed on at least three levels. First, for many digital products, the sticker price to the consumer is free but we pay in other ways: in kind, with our data and in money, through the products we buy once we click a personalised advert. We pay also through exposure to addictive apps, disinformation, online hate and the subversion of democracy.

A second example can be seen in the profound impacts of corporate activities on the environment. Prices do not capture the negative externalities of production, for which neither the producer nor the consumer pays. These unaccounted costs have brought us to the brink of ecosystem collapse. Again, low consumer prices are not an adequate benchmark.

Third, and relatedly, we are not just consumers. We are also workers, parents, citizens, communities and inhabitants of this fragile planet. The power of business over these aspects of our lives surely matters too, and a focus on low prices often works directly against those interests. The low price/low wage spiral keeps us pushing for cheap goods and services as consumers because as workers we are paid less and less to make them. Low prices crystallise the unequal bargaining positions of zero-hour workers and independent suppliers against powerful employers and buyers. When the farmers feeding the nation are forced to visit food banks, cheaper chickens in our supermarkets cannot be the solution.

Most consumers do not need persuading; however, they might not be aware that we have on the books a law that is capable of challenging corporate conduct at an existential level. By ignoring these other facets of power, competition law is not serving the public interest. The wealthy are able to jump out of the way of the passing combine harvester, following in its wake to scoop up the bountiful products and generous dividends it produces. Meanwhile, the impacts on the poor compound, further embedding systemic race, gender and class disparities, as well as the exploitation of the Global South.

Putting the brakes on

Clearly regulation has a role to play in protecting us from the worst corporate abuses. This implicates a whole host of regulatory regimes, from corporate tax to environmental law to employment rights. But beyond a certain point, the machine becomes too powerful and regulation cannot catch up; indeed, the machine begins to shape the regulation.

The origins of modern competition law lie in the American tradition of anti-trust and anti-monopoly, which saw economic concentrations of power as a fundamental threat to liberty and democracy. At the turn of the 19th century, the robber baron enterprises were often referred to as ‘combines’ because they rolled up whole industries into singular monopolies. Now we need a new vision of competition, and a new role for competition law, which acknowledges the latent threat of these powerful combines and seeks to harness that power for the public good. We must promote not the efficiency of the static machine but instead the integrity of the markets and the balance of power between the state and private enterprise.

Solutions fall into three categories, the three D’s. First, Disperse: we must disperse power using the full potential of the law to block future mergers and break up existing monopolies. Second, Democratise: any power that cannot be dispersed should be democratised by giving stakeholders representation at board level and by creating countervailing structures of power through cooperative business models and unionisation. Third, Dissolve: power that resists dispersal and democratisation, and which consistently breaches the public interest, should be dissolved by having the privileges of incorporation revoked.

Such a vision of corporate regulation could underpin a very different model of capitalism, one that is no longer synonymous with rentier finance and monopolistic power. The balance of power would be served by constraining the influence of concentrated capital; by empowering the currently disempowered to challenge monopolies and enabling stakeholders to stake a claim in the economy; and by democratising corporations and sharing the benefits of their power.

Economic security and resilience depend on the principles of freedom, democracy and fairness. They also depend on true economic responsiveness and dynamism. Monopolised industry ossifies, fixing its contours around the interest of the incumbents, not of the public. Path dependency sets in as we are forced to follow the tracks cut by the combines. Competition law must catch up to these powerful machines. Only by modulating their power will we be able to share the benefits of capitalism more widely. ■

DOES MMT ADD UP?

As we face a series of existential crises, it might be time to turn to modern monetary theory

by Bill Mitchell

In 2013, philosopher Daniel Dennett said in reference to religion: “There’s simply no polite way to tell people they’ve dedicated their lives to an illusion.” The same applies to our embrace of mainstream macroeconomics, which, given its appalling predictive performance over many years, falls into the category of religion. For example, since the 1990s, Japan has run large public deficits and accumulated the highest level of public debt in the world (and its central bank has been buying most of this debt). Mainstream economists predicted rising interest rates and bond yields, accelerating inflation and, inevitably, government insolvency. All predictions failed dramatically.

Similar predictions of disaster were made during the global financial crisis, when many governments followed the Japanese example. But the predictions were grossly inaccurate – because the underlying economic theory is wrong. Austerity-obsessed governments, applying that flawed theory, have forced their nations to endure slower output and productivity growth, degraded public services and infrastructure, elevated and persistent unemployment and underemployment, flat wage growth, and rising poverty rates and inequality. Neoliberalism fails to deliver, and the theories used to justify it are wrong.

An alternative macroeconomics paradigm – modern monetary theory (MMT) – is attracting attention because it provides an accurate understanding of real-world monetary systems that allows for better policy formulation to meet the social, health and climate challenges before us. A mainstream economics graduate can say nothing sensible about public policy.

MMT teaches us that a household uses its country’s currency and its spending is financially constrained.

The government that issues this currency is not so constrained. It can never run out of its own currency and can purchase anything for sale in that currency, including all idle labour. Mass unemployment is always a political choice. Government spending is only limited by the availability of goods and services. If productive resources are idle, government spending can always bring them back into use, without generating inflation. The role of fiscal policy is to ensure all productive resources are fully employed; to maximise material prosperity within ecological constraints. It is not to achieve some financial outcome (surplus or otherwise). At full employment, any further public spending growth will cause inflation. At that point, a government wishing to increase its resource use has to reduce non-government usage. Taxation achieves this purpose by curtailing private purchasing power. But it is not required to fund public spending.

Why have Japan’s huge deficits, largely funded by central bank money, not been inflationary? Because the government maintains total spending in proportion to available goods and services and the non-government sector chooses to save. Why are bond yields low in the face of large public debt? Because central banks can always control yields through bond purchases. Private markets can never push yields up if the government does not allow them to. MMT is often dismissed as flawed and unrealistic. But mainstream economic theory has shown time and again that it cannot effectively tackle the challenges facing the world today. It is time for a change. ■



Bill Mitchell is the Chair in Economics and Director of the Centre of Full Employment and Equity at the University of Newcastle, Australia. He is the co-author of *Macroeconomics*

THE NATURE OF THINGS

We need to include natural capital in our economic systems in order to create a sustainable future

by Alexandra Pinzón Torres
 @alex_pintor11

The ecological footprint of human beings has far exceeded the regenerative capacity of the biosphere. Government intervention to tackle the Covid-19 pandemic has involved more expenditure or less public revenue, or both, amid mounting sovereign debt risks, especially for emerging markets. Growing our way out of the crisis – along with significant sums of government expenditure – would be ideal. But how we grow matters.

The economics of natural capital

As the interim report of the Dasgupta Review, an independent review on the economics of biodiversity commissioned by the UK government and written by Sir Partha Dasgupta, explains, our current way of looking at growth considers the economic system as separate to the natural world. Sir Partha proposes that we acknowledge our economies are embedded in the biosphere. There is no economy without this and our economic – and societal – prospects are intrinsically tied to the destiny of the natural system of which we are part. The biosphere and its regenerative capacity represent an upper limit to our economic demands.

If we think of natural capital as a fund and ecosystem services as the interest, our long-term use of the fund is only sustainable if we withdraw within the value of the interest cashflow stream. Always spending over this amount (as we are currently doing) means we are depleting capital. An ever-smaller capital base will generate lower returns until nothing is left. We need a new economic paradigm that incorporates nature as both a boundary system – showing us where our limits are – and a pillar of growth.

Although 55% of global GDP is moderately to highly dependent on natural capital, according to the insurance firm Swiss Re, our economic growth equations ignore this fact. But the loss of natural capital will affect countries' production across all sectors and will increase risk mitigation costs for the global economy. For example, soil fertility, water supply and moderate temperatures are indispensable, as they are needed to produce our food; once damaged, lost or irrevocably altered these can be costly or impossible to replace. Economic sectors are dependent on natural capital, but are destroying and polluting their own resources. This is clearly not tenable.

According to the Intergovernmental Science-Policy Platform on Biodiversity and Ecosystem Services, the global rate of species extinction is at least 10 to hundreds of times higher than the average rate over the past 10 million years. Over a third of our global land surface and two-thirds of our surface water are devoted to crop and livestock production, displacing many species from their natural habitat. Growing populations and increasing economic activity demand inputs from our natural system and impose heavy burdens on it, resulting in natural capital loss.

It is to each country's benefit to preserve and regenerate their natural capital. Yet a study by the Paulson Institute, the Nature Conservancy and the Cornell Atkinson Center for Sustainability estimated that in 2019 the finance provided for biodiversity protection amounted to only \$124bn–\$143bn; compare this with figures from the same study which estimate that we need to spend \$722bn–\$967bn per year over the next 10 years to effectively tackle ▶

Alexandra Pinzón Torres is an environmental economist. She is transitioning from her former Policy Fellow role at the Grantham Research Institute at LSE to helping manage international carbon emissions reductions projects



biodiversity loss. The risk of depleting biodiversity is particularly high in emerging markets, which often have high stocks of natural capital and a pressing need for poverty alleviation and jobs. The obvious solution is to use these natural resources to kickstart the economy and generate jobs and prosperity. But this is a false economy.

Six proposals

Thankfully, public understanding of climate change has improved over recent decades and there is greater acceptance that it poses an existential and financial risk. We have advanced in the ways we discuss it and in trialling ways to address it, for example, on carbon pricing. However, natural capital is more complex, as it is composed of so many different elements that are interconnected and depend on one another, with the health of these components all measured in different ways. Despite this, natural capital regeneration and climate change mitigation and adaptation share some fundamental problems and, as a result, solutions. The six proposals below use the similarities between both to address the question of sustainable growth, one that accounts for our dependency on nature.

First, we need to encourage financial sector engagement in the post-2020 biodiversity framework and its financing mechanisms. This means embedding natural capital and biodiversity at the core of financial decision-making. Information exchange and collaboration between the financial sector and the Convention on Biological Diversity (CBD) – a multilateral treaty signed by 30 states – would be a welcome step (and the CBD is calling for this).

The financial sector can play a catalytic role by formalising and mainstreaming its engagement with governments across the world to help advance the alignment of national policies with natural capital protection and regeneration. Earlier this year, for example, more than 30 funds with over \$4.6tn in assets joined to pressure the Brazilian government to end its policies that are destroying the Amazon rainforest. These efforts were the start of a wider plan to engage with the Brazilian government and led to a temporary ban on setting fires in the rainforest. Investors should bring this type of policy engagement into the mainstream as part of their relationship with global sovereign debt issuers; as natural capital loss translates into economic risk, they have good reason to do so. This would signal that access to financial markets is highly dependent on protecting nature and promoting regeneration.

Governments issue sovereign debt to fund their policies, including those which promote social and

economic development. Bringing sovereign debt into alignment with natural capital boundaries requires addressing the trade-off between natural capital preservation and economic development that is apparent in these policies.

Second, we need to address the incentive problem. Natural capital loss and climate change are the results of our longstanding lack of understanding (or deliberate ignorance) about the negative effect of untrammelled economic activity on the natural world and climate. As the World Bank highlights in its 2020 report, *Mobilizing Private Finance for Nature*, we currently have various short-sighted policies that prioritise production and its corresponding instruments and incentives. The actors that depend on natural capital for their activities and profits are those despoiling our natural capital and biodiversity, but they do not pay the full cost of their contributions to climate change or environmental degradation. In a way, we as a society are subsidising them.

A way to address the problem of perverse incentives is to identify, assess and reform subsidies that are harmful to biodiversity. The OECD estimates that government subsidies for activities that exploit nature amount to \$4tn–\$6tn per year globally. Such subsidies are entrenched in national economic policies, and it falls within the remit of national governments to develop policies that are consistent with regenerating nature. These perverse subsidies are a clear case of governmental focus on the short term to the detriment of long-term macroeconomic performance.

Third, we need to ‘internalise’ the value of nature, building it into all of our societal systems. Given the complexity of natural capital and biodiversity, it is nearly impossible to reduce targets to a number that is equivalent to greenhouse gas emissions. It is an area that needs much more expert discussion, including the participation of indigenous peoples. As the stewards of many of our remaining natural-capital-rich areas, indigenous people have a wealth of knowledge to share. We need to agree on the right metrics and start embedding the cost of biodiversity loss not only in businesses’ accounts but countries’ national accounts.

Fourth, we need to create a transparent monitoring and reporting framework at the sovereign level. The CBD is designing a post-2020 global biodiversity framework. We can only achieve its 2050 vision of valuing, conserving, restoring and using biodiversity wisely through international consensus on targets and transparent implementation of agreed commitments. Governments should agree on comparable metrics to report their progress on shared biodiversity targets, preferably with plans for policy alignment. As the CBD

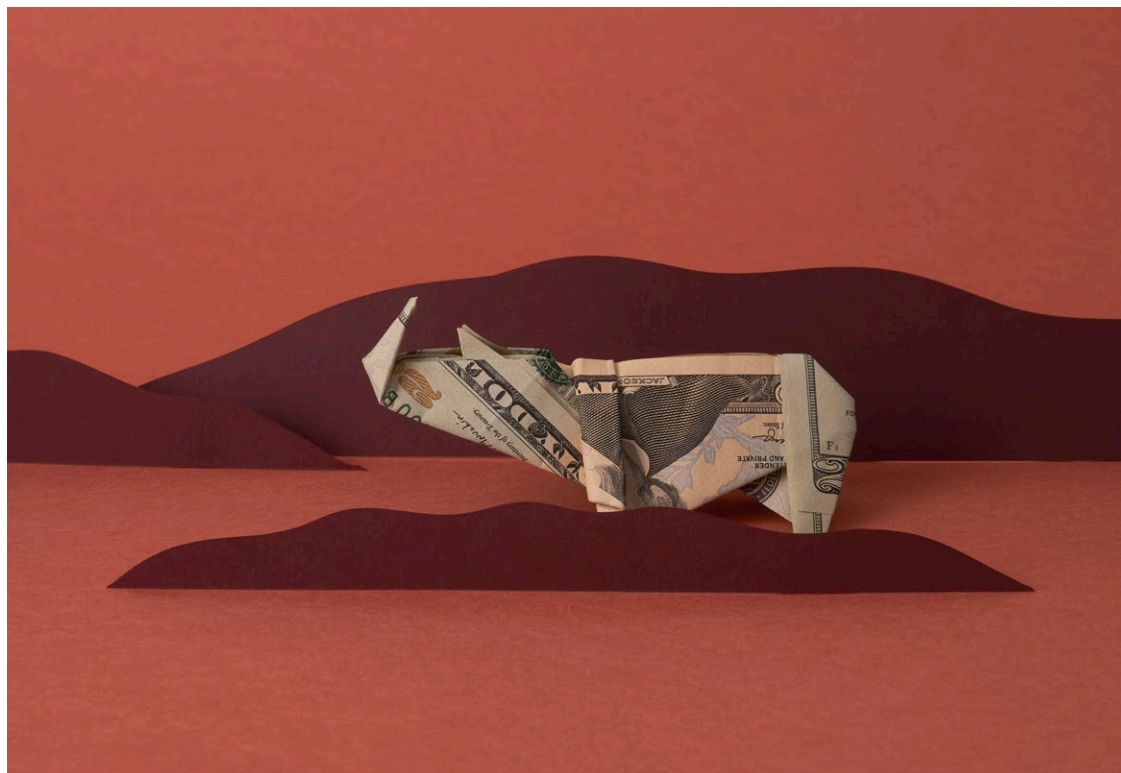

highlights, transparent reporting would also allow swift corrective action to be taken when required.

Fifth, international financing must be provided for natural capital preservation and regeneration in countries with a high natural capital stock. Much of the world's remaining natural capital is concentrated in emerging markets. We need to design compensation mechanisms tied to demonstrable work on preservation and regeneration of natural capital in these countries, and to incentivise their leapfrogging to a model of development with nature as a boundary and a pillar. The shift to this new paradigm is likely to require at least two sources of finance: grants to support the early stages of design and implementation for emerging markets, and financial instruments designed to reward countries rich in natural capital for transparently achieving their biodiversity and natural capital targets. These financial incentives can take the form of payments for biodiversity and natural capital protection – building on the idea of carbon credits – and parallel incorporation of the critical role of natural capital for long-term macroeconomic performance and risk mitigation in sovereign debt pricing.

And finally, we need to provide technical assistance and support capacity-building efforts. This will be necessary for countries – particularly emerging economies – to engage in the reformation of their policy frameworks and corresponding incentives.

Building a resilient future

The recommendations above would help define the right incentives for changing our conception of economic activity to see it as intrinsically embedded within the boundaries of the biosphere, as the Dasgupta Review suggests. They are not exhaustive, but they are a start.

Covid-19 has demanded unprecedented fiscal intervention, amounting already to \$12tn, or 12% of global GDP. This public expenditure increase has come at a time of concerning debt build-up across emerging markets, making it even harder for low- and middle-income countries in particular to access additional finance, which is needed now more than ever. Sovereign debt defaults remain a genuine risk for these economies.

Eliminating perverse incentives and channelling government expenditure towards resilience – including afforestation projects, parkland expansion and enhancement of rural ecosystems – allows fast implementation of low-requirement and shovel-ready projects that are also significant job multipliers. By addressing and accepting our dependency on nature, we can start to overhaul our economic system to create one that is sustainable. This is not simply a 'nice to have'; it is essential if we are to continue to achieve economic prosperity not only for our generation, but for generations to come. ■

UNSTEADY FOUNDATIONS

The importance of the built environment cannot be underestimated; it can make or break cities

by Marwa Al-Sabouni
 @marwa_alsabouni

‘A vacation house, two bedrooms, two bathrooms, open kitchen, and a living area. With a view right across the sandy beach. For price information send a DM.’

If you are reading this, you do not have to send a DM: the price is \$650,000. The location is not Malibu, nor the Maldives, but Tartous in Syria. Yes, bomb-shelled Syria, where significant parts of the cities have been reduced to rubble, where there have been incredible economic losses, and where more than half of the population are now either internally displaced, living in refugee camps, or are asylum seekers. The Syria where 83% of the population today live below the poverty line.

The beach house advert is one of many that offer properties ranging between \$600,000 and \$1m. And the advert is not foolishly hubristic: there are actually people who are willing and able to pay these prices. But for the vast majority of Syrians, homes with a \$650,000 price tag are outside the realm of possibility. Nonetheless, real estate prices in ‘desirable’ areas are as high as ever, and so is the dream of home.

When I wrote *The Battle for Home*, Syrian cities, including mine, were still under fire. The full extent of the damage was not yet clear, but I saw how the transformations in our built environment had paved the way for such a collapse. Our city planners,

influenced by the French colonial legacy, changed our cities so that they were no longer inclusive, nature-friendly, self-sustaining havens, but were instead segregated, compartmentalised ghettos. The loss of our sense of belonging made us much more ready to lose ourselves to the cycle of destruction and civil war. The connection between how we build and how we live never seemed more pertinent to me than during those times of death and destruction.

However, what surprised me was how global the Syrian story turned out to be. It’s true that the world does not suffer our political problems, but it is definitely displaying similar architectural and urban symptoms, such as segregational zoning, city centres aimed at tourists rather than locals and faceless buildings.

The value of home

The real value of things corresponds with the production cost, including labour, shipping, marketing and other aspects that are tangible and can be measured. But the perceived value is where things become trickier. This is the customer’s measurement of an item’s value, and does not lend itself so easily to set metrics. In the arts, an artist’s talent and craft – and their reputation – imbue their work with a value. But when it comes to architecture, which encompasses

Marwa Al-Sabouni is an architect based in Homs, Syria. Her first book, *The Battle for Home: The Vision of a Young Architect in Syria*, was published in 2016. Her next book, *Building for Hope*, will be out in April 2021



the practical arts and big industry, the market value relies heavily on social zoning.

The beach house, taken just as a building, may not be worth more than a few thousand dollars to cover the costs of the building materials and the facilities provided. There is no special expertise involved, nor ‘invaluable’ artistic craftsmanship, in building this simple structure. The only factor that raises its price is its social surroundings; the ‘type’ of people living nearby. Architecture is the only form of art that does not take its value from its makers, rather it takes it from its users.

Architects are essential players in this game of segregation. It all begins with designing a sign language of forms meant to distinguish and separate: bigger scales, extravagance, gated communities and so on.

The tapestry of the urban environment

As people learn to recognise these signs, they want to have this outward marker of prosperity. Neighbourhoods start to spring up based not on social knots created organically over time, but delineated along lines of wealth. Neighbours are substituted with lifestyle-matching peers. Neighbourhoods which benefited once from the collaborative and supporting environment of a community rely today on what literally counts: money.

This is a very dangerous slope. The higher the price of real estate, the deeper the inequality among people. This is a matter of life or death for cities. Because when the prices of homes go up, so do the prices of everything else. A store that has to pay considerable rent due to its location will add those extra costs to its products, creating a chain of inflated value. At some point, as Syria – among others – has shown us, the chain will collapse, and an explosion becomes inevitable.

So what can be done? My search for answers led me to the old Islamic cities, where Muslims and Christians, poor and rich, lived side by side. Their survival offers solutions to the spiral of problems of the modern city. The buildings’ outer appearances were organised around principles of modesty and privacy, craftsmanship and creativity, and – most importantly – a sense of respect for everything, from nature to neighbour. This was woven into the tapestry of the urban environment, and was then reflected in the social fabric.

In Syria today, few can afford multi-million-dollar leisure properties with ample outdoor space, so people picnic on the green patches beside the roads. Those who pass by in expensive cars sneer at that ‘vulgar’ choice. I cannot help but ask myself: is it the beginning of another chain of destructive antagonism? ■

POST-COVID-19 SCHOOLING

Schools need to be at the heart of a new covenant between the government and our children

by Mark Londesborough

🐦 @st_reatham

The first rainbow, so the Bible says, was a sign of a covenant between God and humanity. A reminder of the bond between the mighty and the weak; that the worst of storms are weathered together.

It is perhaps no surprise then, that as the UK locked down in March, some of the first signs of hope in the midst of our fear and confusion were the rainbows appearing in windows. Made by children, they served as a reminder not only of collective support for the NHS, but also of the covenant between the people and the state; that we have chosen to look after the most vulnerable members of our community together.

This idea is central to MP Danny Kruger's recent report to government on what the Prime Minister's goal of "levelling up" really means. Kruger defines the covenant as "the mutual commitment by citizens, civil society, businesses and the state, each to fulfil their discrete responsibilities and to work together for the common good of all". So, how did the covenant with our children fare during the 'great pause'?

According to the Office of the Children's Commissioner, 575m school days were missed between March and July 2020. Even now, as schools attempt to limit the spread of infection, attendance remains patchy: ranging from 61% in Knowsley to 94% in Kensington and Chelsea. While schools have provided remote learning alternatives, children's ability to access them varies. Ofcom estimates that between 1.14 million and 1.78 million children in the UK do not have access to a laptop, desktop or tablet in their homes.

While schools remained open for the most vulnerable children, only 8% were attending before schools started to reopen in June. Only 6% of children with education health and care plans (EHCPs) attended school during that same period, rising to 28% in July; 72% were still absent. The Coronavirus Act 2020 changed the level of obligation on local authorities and health bodies, requiring them only to make "reasonable endeavours" to deliver services that these children would ordinarily be entitled to. This led to a huge drop in access to services. Meanwhile, Ofsted research indicates that many younger children have not returned to early years education settings and, of those that have, many are more anxious and have regressed in their learning and development.

Before the crisis, nearly 2.2 million children in England were living in households affected by one or more of the 'toxic trio' of family issues: domestic abuse, parental drug and/or alcohol dependency, and severe parental mental health issues. Covid-19 has significantly exacerbated these problems, while the number of children referred to social services has fallen.

The covenant is broken

These aren't just the unfortunate consequences of the pandemic, but signs that the covenant is broken. Schools have innovated. Teachers' understanding of how to harness technology has massively improved. Individuals have stepped in to make sure that disadvantaged children do not go hungry during school holidays. But the government's attempts to

Mark Londesborough is the RSA's Associate Director of Creative Learning and Development

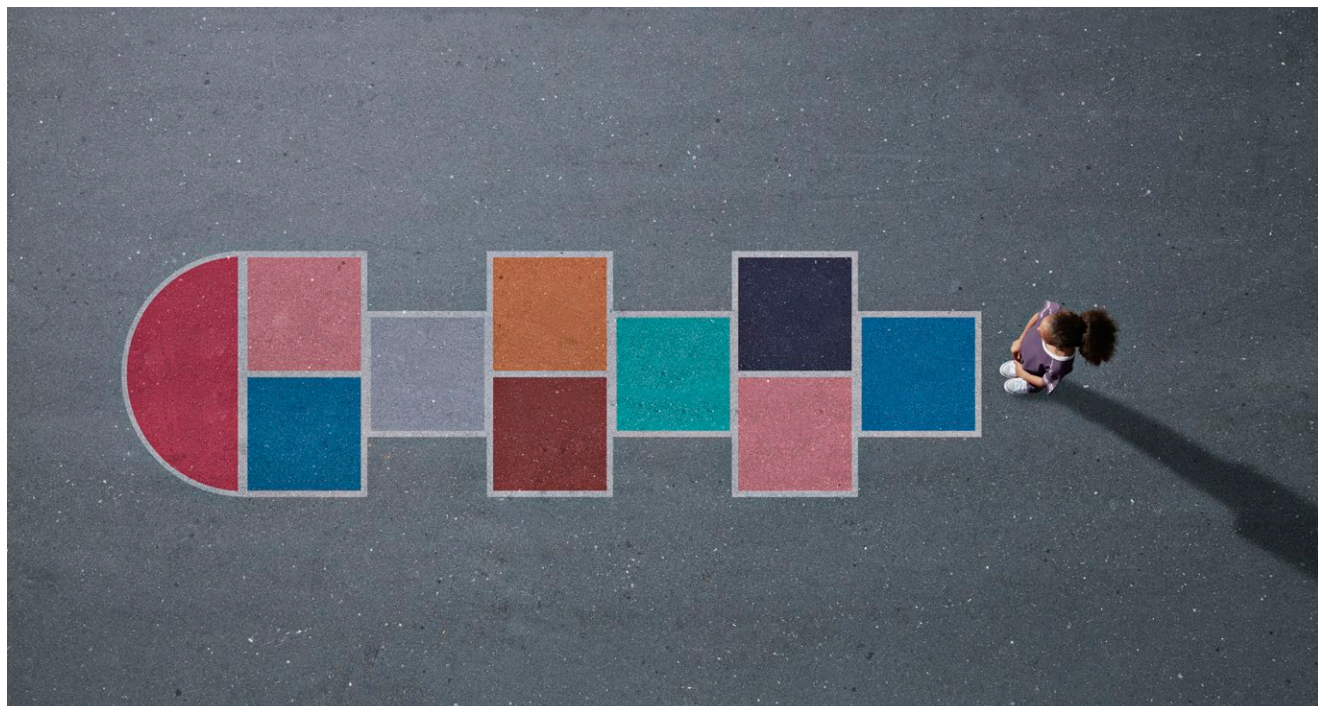

fulfil its responsibilities have been a succession of unpopular, confusing failings, from the fiasco around exam results to the failure to distribute sufficient technology to disadvantaged pupils at home.

In ignoring Marcus Rashford's call for funding for free school meals in the holidays the second time around, the government claimed a victory for civil society, but ignored a growing consensus: that it has misunderstood the role of education and must take stronger action to ensure fairness in the system. Covid-19 has provided a strong reminder of schools' dual role as learning institutions and a critical part of the local social fabric. This has created an opportunity to encourage a more expansive, more inclusive way of assessing the success of students, schools and the system.

The exam fiasco also highlighted the built-in unfairness of England's exam system. When a third of children are required to fail every year, assessing schools' success by measuring students' performance in exams stops making sense. More than that, in a context where school curriculums have been narrowed and hollowed out, the 30% of 16-year-olds not achieving a grade 4 or higher in their English and maths GCSEs leave with a very real sense of having entirely failed in their education. For too many this sets the tone for their future, and these young people are already more likely to be disadvantaged when they enter formal education.

All children deserve a rich education: one that supports academic achievement, but also sets them up for life. The RSA is in the early stages of developing a

new research programme that will help translate the growing consensus around an inclusive understanding of schools' functions into practical ways to change the system. This will focus on three areas.

First, promoting the idea – well articulated by Stephen Tierney FRSA in his book *Educating With Purpose* – that schools' main purpose is to provide the foundations for children's lifelong personal flourishing and their ability and desire to contribute towards others' flourishing. Fulfilling that purpose means recognising the role schools play in developing a wide range of capabilities, including, but not limited to, academic achievement.

Second, promoting an understanding of schools as civic institutions which, when they are integrated with the world beyond their gates, contribute to the advancement of communities, not just individual students. The RSA Academies have worked to develop a self-assessment framework for schools' engagement between school and community. The RSA will build this and its Pinball Kids project to co-design collaborative, place-based mechanisms for preventing school exclusions.

Third, encouraging creativity and disciplined innovation in new approaches to pedagogy, assessment, and school and curriculum design and operation: the mechanisms through which a fairer education will be delivered.

As news of a vaccine signals, perhaps, an end to the crisis, the RSA and its Fellowship now have a responsibility to help identify and amplify consensus on the need for change. ■

THE BRAIN ECONOMY

An economy based around psychological and cognitive wellness would enable us to create a stronger, more resilient future

by Harris A Eyre, Anika Sinha, Erin Smith, Sandra B Chapman, Alan Kirman, Cara Altimus, Marion Leboyer and William Hynes
✉@harrisaeyre

In light of the many disruptions the world faces as a result of the Covid-19 pandemic, the World Economic Forum (WEF) has developed its Great Reset initiative. This looks to the ways we can shape the recovery and the future of economies, societies, businesses and governments. The WEF argues that part of this reset should include a shift to developing more sustainable business models, such as an impact economy. This would be based on taking into account social goods and external harms alongside profits.

In an impact economy, the norms that are attached to the pursuit of social impact would be as widely accepted, consistent and stable as the norms that are associated with the pursuit of profit. Similar to the changing perceptions surrounding sustainability reporting and business practices, financial investors recognise that social impact drives stable returns.

This shift has already begun; the Global Reporting Initiative, in partnership with the Robert Wood Johnson Foundation, has developed health metrics geared toward the inclusion of social impact in current sustainability indexes. Encouraged by the added measure of certainty and transparency surrounding their activities, the aim is that investors will allocate more capital to financing initiatives that have positive social outcomes, and that entrepreneurs will devise business models along the same lines. A further aim is to drive consumer choices so that a greater share of their spending goes to social enterprises.

Brain capital

We propose that a similar approach should be taken regarding the impact of company and governmental practices on brain capital.

Brain capital puts a premium on brain health and brain skills. The former encompasses emotional, behavioural and cognitive health across an individual's lifespan. Compromised brain health greatly increases the risk of depression, anxiety, substance misuse, dementias, and neurodevelopmental and neurocognitive disorders. As well as potentially devastating consequences for individuals and their loved ones, such disorders are estimated to cost the global economy \$2.5tn–\$8.5tn per year in lost productivity. Covid-19 has likely added to this figure, as isolation, unemployment and insecurity have put additional pressures on people's brain health.

Brain skills include self-control, emotional intelligence, creativity, compassion, altruism, systems thinking and cognitive flexibility; all are critical in a digitised economy, and all are dependent on good brain health. Brain skills are also critical for resilience and adaptability, two traits that are now more important than ever. A digitised economy – which places a premium on cerebral rather than manual skills – can be thought of as a brain economy. Brain capital is crucial in this context, where automation is accelerating and where innovation is a tangible and increasingly pivotal 'deliverable' of employee productivity. ▶



Image from Yellow Images

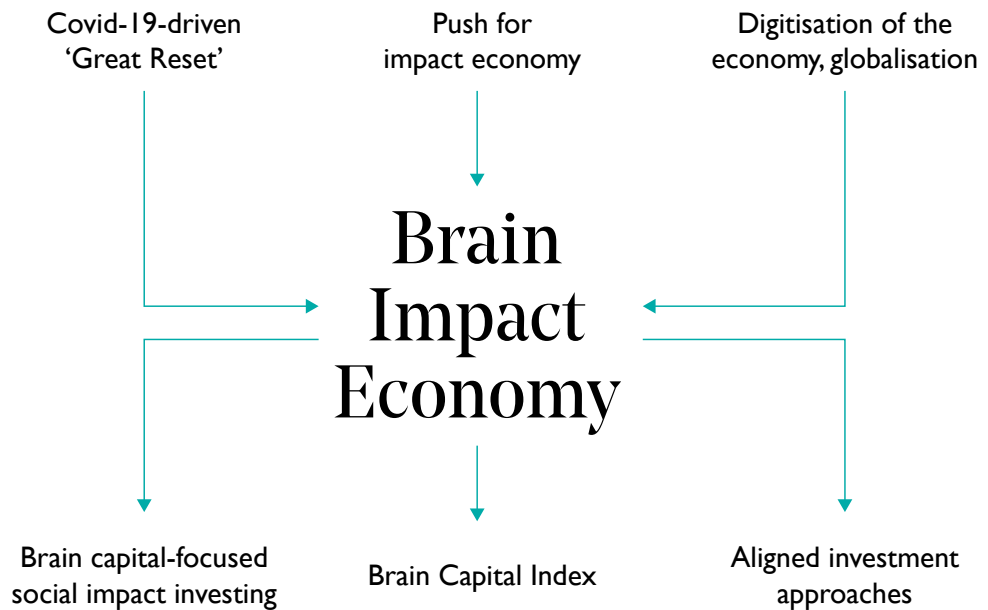

Bringing together the ethos of the impact economy and the brain economy would provide the kind of economic reimagination we so clearly need. A brain impact economy would be one where the practices, policies and standards attached to the pursuit of optimal brain capital would be as widely accepted as the norms associated with the pursuit of financial profit. Governments and business leaders would recognise that economic and business activity are modulated by the mental capacity of their people.

Fuelling a brain impact economy

There are a range of investment and innovation approaches that could fuel the brain impact economy. Establishing Brain Health Living Labs – units which integrate concurrent clinical care, research and innovation processes with a public-private-people partnership – would speed up the development of well-designed, evidence-based brain health solutions through a user-centred, iterative, open-innovation ecosystem. Funding should be channelled to medical innovation companies and early-stage technologies, healthy brain bonds (which would support brain health and scale up support services) should be developed and philanthropy used to direct support.

Social impact investments have the specific aim of generating positive, measurable social and environmental impact alongside a financial return. This kind of outcomes-based investment allows

public-sector entities (including governments) to pay only for what works and to the extent that it works. At the same time, they create pathways for the most impactful providers and interventions to grow if they can achieve key policy priorities.

Social impact investing can be relevant to building brain capital. It can support investment in approaches to education that can optimise opportunities and success in life and are inversely associated with rates of depression and dementia.

For example, the Chicago Child-Parent Center Pay for Success Initiative, launched in 2014, aims to improve school readiness and decrease use of special education services by providing high-quality pre-kindergarten care and parent engagement services to low-income families. It is based on the Child-Parent Center model, an early-childhood preschool approach that emphasises aligned education and services in high-needs communities. The programme served 2,618 four-year-old children living in Chicago Public Schools Title I attendance areas (neighbourhoods with the highest poverty rates) over a four-year term. (There is now a 17-year repayment term and evaluation period.) This intervention aligns with the skill theory as posited by economists Flavio Cunha and James Heckman, which suggests that skills built in early life serve as a scaffold for the development of later skills and health. The Child-Parent Center model has also been demonstrated to be cost-beneficial and associated

with higher rates of high school completion, lower rates of juvenile arrest and arrest for a violent offence, and reductions in special education placement, grade retention and child maltreatment.

When it comes to brain skills, the Career Impact Bond (CIB) is a ‘pay for success’ financing tool that provides students with affordable, high-quality workforce training for in-demand careers. CIBs have been developed and pioneered by Social Finance, a social impact firm. The bond expands access to training for people from low-income communities and those who face barriers to education and employment.

With CIBs, impact investors provide catalytic capital to training providers, which use the funds to cover a portion of the upfront training costs and deliver critical support services for typically underserved students. Students enroll free of charge, and those who gain meaningful employment after graduation repay programme costs as a fixed percentage of their income, capped at a certain amount and for a certain period of time, with the payments shared between impact investors and training providers. Those who do not obtain and maintain meaningful employment following graduation pay nothing.

Regulation

The taxation and accounting restructuring needed to support the brain impact economy could be guided by the principles of the Human Capital Accounting Framework, recently published by the WEF and Willis Towers Watson. This recognises that human capital can be a company’s greatest asset and can make or break a business strategy. According to the Global Intangible Finance Tracker, a company’s intangible assets, including human capital and culture, are estimated to comprise close to half of a company’s market value. This framework could enable companies to monitor and assess the return on their investments in their employees in the same way that they measure returns on financial and intellectual capital.

There are a number of organisations driving these efforts, including the US Securities and Exchange Commission (SEC), which is looking to expand reporting requirements to include a broad set of measures including training hours, worker productivity and turnover. The Human Capital Management Coalition, representing major institutional investors, has been pivotal in petitioning the SEC to move in the direction of requiring human capital metric reporting. The International Financial Reporting Standards Foundation and US Financial Accounting Standards Board both have requirements in place for reporting employee–employer transaction information related to employee benefits, retirement

plans and compensation. Recently, the International Organization for Standardization specified 23 core metrics – including costs and worker productivity, health and wellbeing, and leadership trust – for organisations to track and report.

The development of a Brain Capital Index (BCI) could help to track the brain capital impacts of companies and governments as well as the value of investments. If such an index were investable – as in the case of a mutual fund or exchange-traded fund – it would encourage investment in the entire space by opening it to the passive investor. Index-tracking funds have recently passed the \$10tn mark of assets under management globally, surpassing assets under active management for the first time. Attracting even a small fraction of global passive investment to use such a model would transform the brain economy as a whole.

A BCI would consider a range of components. Health-related metrics may include incidence and prevalence metrics, access to care and relapse rates. Access to mental healthcare for children and young people, for instance, is of paramount importance, so coverage for families and employees should be prioritised. The demand for mental healthcare is at an all-time high, but the ratio of professionals to patients is incredibly low, hence this ratio should be tracked.

We might also choose to track purpose in work, given this is shown in the Rush Memory and Aging project to have a range of brain health benefits, including reducing the likelihood of dementia and strokes.

There are already models out there we can learn from. For example, the California-based One Mind at Work, a workplace mental health organisation, has worked with Total Brain to develop a Mental Health Index that uses standardised, scientifically based digital assessment and questions to measure a person’s 12 brain capacities across the areas of emotion, feeling, cognition and self-control. The assessment screens for risk of seven common mental health conditions and acts as a sort of mental health thermometer.

Such a radical shift towards an economy that centres on our brain health will require a lot of work. Data privacy and ethical issues must be considered. Indexes should be de-identified and considered in aggregate. Technologies should be built with responsible innovation principles in mind. But such an approach begins to address the fundamental question at the heart of the Great Reset: what is a valuable impact and how will we measure it? Our answers to this question will define the world’s progress in the wake of Covid-19.

The world is experiencing an identity crisis; how we emerge will define the next generations. To prepare to solve increasingly complex and urgent global issues, brain capital must be an axiom of progress. ■

ALLIANCES TO FACE A CRISIS

The Covid-19 pandemic has encouraged Fellows to get together and take action

by Alexa Clay, Jamie Cooke and Philipa Duthie
 @alexaclay @JamieACooke @theRSA_ANZ

In response to the Covid-19 pandemic, a growing number of groups have gained in prominence, looking to rise to the structural, social and economic challenges laid bare by the crisis. Policy ideas that were once deemed to be utopian or marginal – from universal basic income (UBI) and cash payments to emergency relief for small businesses to radical criminal justice reform – are increasingly being embraced with urgency and pragmatism.

How can we channel this spirit of creativity and urgency into recovery plans, systemic solutions and long-term strategic policymaking? Part of the answer is collective action, and this means unleashing the potential of networks to make real-world practical change. Over the past few months, members of the RSA Fellowship have shared and developed a range of ideas, innovations and examples of cooperation. Collaboration with other networks has only further demonstrated the power of working together.

Towards a new economic system

Fellows in Scotland have been working with the Wellbeing Economy Alliance, a global effort between organisations, alliances and individuals who seek to shift typical economic narratives and create a wellbeing economy. It sees collaboration as key to bringing about real change and has helped bring countries, including Scotland and New Zealand, into a discussion on new economic models.

Meanwhile, RSA US has been developing innovative opportunities for influencing change through place-

based coalitions examining issues such as green jobs, energy transition, anti-racism, and citizen voice and deliberation as the bedrock of regional inclusive growth policies. At a time when crisis can create a climate ripe for authoritarian policymaking, we have been pushing for more dialogue and for democratic and deliberative means of establishing economic recovery.

In that spirit, an exciting partnership has been developing over the past few years between the cities of Glasgow and Pittsburgh, led by Fellows in each instance. Both places have experienced huge losses due to industrial decline – conditions which have been further accentuated by Covid-19 – and share a desire to create more sustainable, resilient structures and systems for the future, which can allow residents to thrive, not just survive. Pittsburgh’s Mayor Bill Peduto has recently signed the city up to the Mayors for a Guaranteed Income network in the US, while Glasgow is one of the cities in Scotland pioneering research into UBI, led by the city government with input from the RSA. The time is ripe for both cities to share their learning and activity on this topic (which has long been a key RSA area of interest and expertise).

In addition, Glasgow and Pittsburgh have been exploring economist Kate Raworth’s work and the model of sustainable, progressive cities she outlines in her book *Doughnut Economics*. This cooperation was prompted by an article by Jamie and will bring together a collaborative partnership of city officials, civic society and RSA Fellows. The launch of Raworth’s Doughnut Economics Action Lab in September looks set to create

Alexa Clay is Director of RSA US, Jamie Cooke is Head of RSA Scotland and Philipa Duthie is Director of RSA Oceania

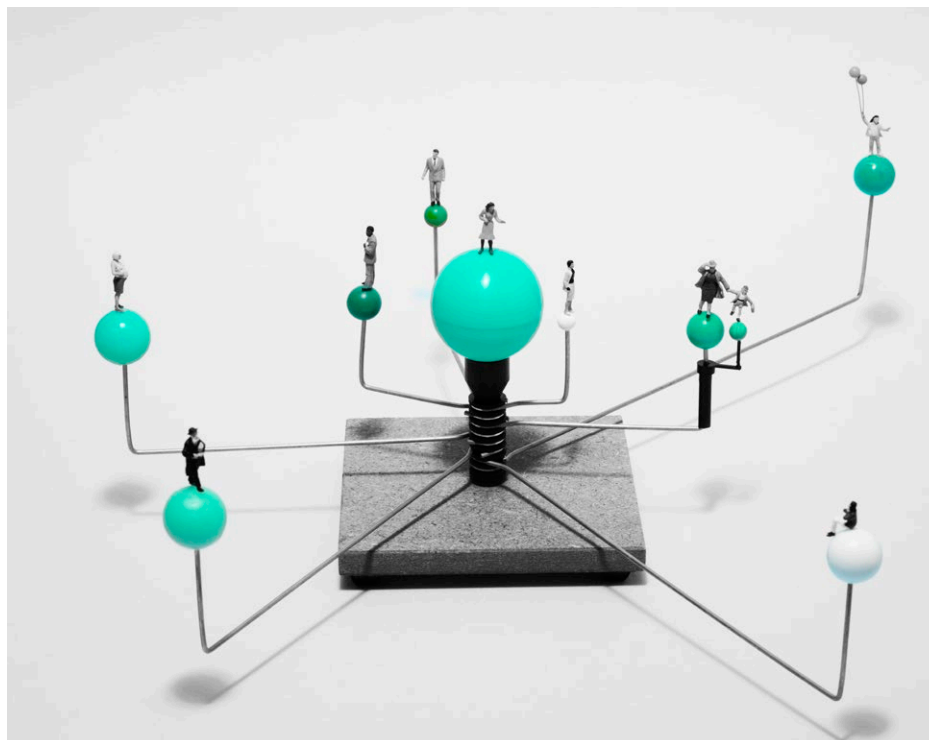

a vibrant community of thinkers and activists across the world who are keen to create change.

Strengthening connections

By capturing and creating innovative and sustainable approaches to change, this work complements the ‘city-to-city’ work that RSA US has been doing to strengthen connections for place-based international learning. A coalition of Fellows from Anchorage, Alaska is learning from plans under way in Helsinki, Finland around energy transition and green recovery. And in New Jersey, RSA US is working with the Office of Innovation to ensure that, in the wake of the Covid-19 crisis, long-term solutions to economic insecurity are being embedded. This is taking place via the development of a Future of Work Accelerator, which will invest in the creation of innovative tools to advance economic security; protect workers’ rights, health and safety; and expand access to benefits. For instance, it may support building a platform for low-wage migrant workers to leave abusive work, or support the scaling up of a company that bundles portable benefits for independent workers. In addition to grassroots innovations, the Accelerator is also looking to attract innovative ideas from public entrepreneurs to help local and regional public servants develop policy ideas that advance a new social contract for good work.

RSA Oceania has been exploring possibilities for the post-pandemic future through a recent six-part online event series, From Crisis to Sustainability, in

collaboration with the Fellow-led RSA Sustainability Network. Aimed at convening a global dialogue between Fellows, the series explored how we can shape a more resilient, socially just and sustainable future. Building back better with more inclusive and sustainable economic models and giving space to diverse perspectives – in particular, traditional knowledge systems and indigenous wisdom – have been consistent threads through the series. Another recurring theme has been the need to adopt a long-term approach to decision-making, not only in terms of implementing effective strategies for the prevention of future social and environmental problems, but also to ensure policies take into account the wellbeing of future generations.

This is just a small sample of RSA activity taking place across the world, with further events in development with Fellows and partners in countries globally. The UK Global team, and our teams in Oceania, the US and Scotland, are always keen to discuss ideas for collaboration and impact, particularly at a time when virtual international participation in events has become the norm. No one city or country will be able to solve the global challenges of Covid-19, the climate emergency or a changing economic environment; the global Fellowship of the RSA can be a powerful force for positive change. ■

■ Visit www.thersa.org/united-states to find out more, or contact Jamie Cooke on jamie.cooke@rsa.org.uk.



SHOPPING

Our purchasing habits have increasingly moved online, but bricks-and-mortar retail therapy isn't finished yet

by Kate Nightingale
@StylePsychology

A typical weekend for many people in the UK prior to our first lockdown in spring included a trip to a high street or shopping centre before maybe a visit to the cinema or another form of entertainment, culminating in a dinner with family or friends. All these places are full of people, smells and conversations, and are aesthetically pleasing. The stimulation our brains get from such activities is unparalleled.

Of course, this changed when lockdown began. With social contact potentially dangerous, any trip outside the house became predominantly functional.

Yet the majority of what we consume is not utilitarian. The pleasure we get from aimlessly strolling down the high street, perusing shop windows, grabbing a coffee and meeting friends is an integral part of our lives.

Human beings are social animals, and the denial of meaningful human interaction is not something we can survive for long. It is our instinct to connect with others, if only by observing. Browsing in a shop is often more about looking at people – what they are buying, how they are putting an outfit together – than simply perusing the latest deals.

Most of us turned to online shopping but found that it did not quite cut it. Although invaluable for getting essentials, we realised how boring it becomes. Scrolling the endless 'sea of sameness' might be a good insomnia remedy but it does nothing in terms of fulfilling our basic needs of belonging and self-actualisation. The lack of rich sensory stimulation was another problem. As much as multisensory experience is possible online,

it is often not delivered. Digital channels rarely rely on senses other than vision. Temple University's Fox School of Business published a study showing that "smellizing" (prompting people to imagine the smell of a product) increases product engagement. It is just one in a series of studies demonstrating the power of sensory imagination and memory.

It is no surprise, then, that physical stores are still the favourite of the majority of shoppers, even those who are digital natives. The experience, the sensory stimulation, the meaningful human contact and the relationship-building are all things customers get from the in-store shopping experience. The simple pleasure of browsing without needing to buy anything has value in itself. Yes, research shows that experiencing pleasure often leads to a purchase being made, but it does not change the fact that the motivation that brings a customer into the store in the first place often has nothing to do with needing to buy something and everything to do with the need to meaningfully connect and engage in a diverse collection of experiences.

The predictions that we will shop way more online post-pandemic fail to appreciate the 'soft' benefits of simply being in a shop. We will continue shopping in physical stores, although they might be more local and will need to adapt to new consumer demands, such as transparency and sustainability.

My hope and prediction is that we will come out of this crisis with a more authentic, transparent, ethical and sustainable form of consumerism. The money we are spending has the power to shape the world. So, what world would you like to live in post-pandemic? ■

Kate Nightingale is a consumer psychologist, human brands expert and founder of Style Psychology, a human experience consultancy